

# WT 68

MULTICHANNELS WEIGHT TRANSMITTER/INDICATOR



## Technical manual

Software version WT6801\_19



**VPG force sensors**

Celtron • Revere • Sensortronics • Tedeá-Huntleigh



# INDEX

<b>PRECAUTIONS</b> .....	6
• WARNING .....	6
<b>INTRODUCTION</b> .....	7
• AVAILABLE VERSIONS .....	7
<b>TECHNICAL CHARACTERISTICS</b> .....	8
<b>INSTALLATION</b> .....	9
• GENERAL .....	9
• OVERALL DIMENSIONS .....	10
• ELECTRICAL INSTALLATION .....	10
• POWER SUPPLY OF THE DEVICE .....	11
• LOAD CELL CONNECTIONS .....	11
• LOAD CELL CONNECTION TABLE .....	12
• LOGIC INPUTS .....	12
• LOGIC OUTPUTS .....	13
• SERIAL COMMUNICATION .....	13
• RS232 .....	13
• RS485 .....	14
• ANALOG OUTPUT (OPTIONAL) .....	14
• USB DEVICE (SPECIFICATION 2.0 COMPLIANT; FULL-SPEED 12 MBPS) .....	15
• OPTIONAL FIELDBUS CONNECTIONS .....	15
• ETHERNET CONNECTION .....	15
• FEATURES .....	15
• ETHERNET CONNECTION: CABLE TYPES AND CONNECTION METHODS .....	16
• ETHERNET/IP CONNECTION .....	17
• PROFINET CONNECTION .....	17
• ETHERCAT CONNECTION .....	18

- MAC ADDRESS IN DEVICES WITH INDUSTRIAL ETHERNET FIELDBUS ..... 18
- PROFIBUS CONNECTION ..... 19
- FRONT PANEL OF THE DEVICE** ..... 20
- STAND-BY FUNCTION ..... 20
- KEYPAD USAGE** ..... 21
- KEYBOARD LOCK/UNLOCK FUNCTIONS ..... 23
- EXIT FROM THE CONFIGURATION MENU ..... 23
- DISPLAY INFORMATION** ..... 24
- ERROR INDICATIONS ..... 24
- OPERATIONAL FUNCTIONS** ..... 25
- GROSS WEIGHT / NET WEIGHT DISPLAY ..... 25
- WEIGHT ZEROING AND AUTO-TARE ..... 25
- ZEROING FUNCTION ..... 26
- AUTO-TARE ..... 26
- TEST FUNCTIONS – RS232 AND RS485 ..... 26
- TEST FUNCTIONS - ANALOG OUTPUT TEST ..... 27
- TEST FUNCTIONS - INPUT/OUTPUT TEST ..... 27
- WEIGHT THRESHOLD PROGRAMMING ..... 28
- WEIGHT ACQUISITION ..... 28
- CONDITIONS FOR WEIGHT ACQUISITION ..... 28
- CONFIGURATION** ..... 29
- GENERAL ..... 29
- PROCEDURE FOR MODIFYING AND ENTERING PARAMETERS ..... 30
- INFO MENU ..... 31
- TEST MENU ..... 32
- SETUP MENU ..... 32
- CONFIGURATION PARAMETERS** ..... 33
- CALIBRATION MENU** ..... 34

<b>LOAD CELL BALANCING</b> .....	37
• AUTOMATIC PROCEDURE.....	37
• BALANCING FACTOR .....	37
• EXAMPLE OF CONFIGURATION/CALIBRATION.....	37
• SET THE FOLLOWING VALUES IN THE CONFIGURATION PARAMETERS.....	38
<b>CALIBRATION WITH STANDARD WEIGHTS</b> .....	39
<b>TABLE CALIBRATION</b> .....	41
• EXITING THE CALIBRATION MENU .....	42
<b>ANALOG OUTPUT PARAMETERS (OPTIONAL)</b> .....	43
• ZERO ADJUSTMENT .....	44
• FS ADJUSTMENT .....	44
<b>CONNECTION PARAMETERS</b> .....	45
<b>RS232</b> .....	45
• COM 2 PARAMETERS – WHEN RS485 IS AVAILABLE .....	47
• COM 2 PARAMETERS – WHEN PROFINET IS AVAILABLE.....	49
• COM 2 PARAMETERS – WHEN ETHERNET/IP IS AVAILABLE .....	50
• COM 2 PARAMETERS WHEN ETHERNET IS PRESENT.....	52
• COM 2 PARAMETERS WHEN PROFIBUS IS PRESENT .....	54
• COM 2 PARAMETERS WHEN ETHERCAT IS PRESENT.....	55
<b>INPUT/OUTPUT PARAMETERS</b> .....	57
<b>WEIGHING PARAMETERS</b> .....	60
<b>FILTER PARAMETERS</b> .....	62
<b>FUNCTIONAL CHARACTERISTICS SETTINGS</b> .....	64
<b>DATE AND TIME ADJUSTMENT</b> .....	66
• OPERATING FUNCTIONS - LOAD CELL SIMULATION .....	66
• OPERATING FUNCTIONS - SINGLE CELL DISPLAY.....	67
• LOAD CELL EMULATION .....	67
• SETUP MEMORY UPLOAD / DOWNLOAD .....	67

<b>TEST FUNCTIONS – IN/OUT TEST</b> .....	68
• DISPLAY FORMAT .....	68
<b>TEST FUNCTIONS – RS232 AND RS485 TEST</b> .....	68
<b>TEST FUNCTIONS – ANALOG OUTPUT TEST</b> .....	69
<b>SERIAL COMMUNICATION PROTOCOLS</b> .....	70
• ASCII PROTOCOL: CONTINUOUS, AUTOMATIC, AND ON-DEMAND .....	70
• WEIGHT STATUS ENCODING TABLE .....	70
• WEIGHT FIELD VALUES .....	71
• CHECKSUM CALCULATIO .....	71
• WEIGHT VARIATION CONDITION FOR AUTOMATIC & MANUAL PROTOCOLS.....	71
• SLAVE PROTOCOL.....	72
• MASTER-SLAVE COMMUNICATION .....	72
• COMMAND FORMAT DESCRIPTION .....	72
• COMMUNICATION ADDRESSING .....	72
• ERROR HANDLING .....	74
• FIELD DESCRIPTIONS AND ENCODING TABLES .....	74
• PRINTER PROTOCOL .....	75
• PRINTING CONDITIONS.....	75
• CONDITIONS REQUIRED FOR PRINTING .....	75
• MODBUS RTU PROTOCOL .....	76
• COMMUNICATION ERROR HANDLING.....	76
• HANDLING ERRORS IN RECEIVED DATA .....	77
• SUPPORTED FUNCTIONS .....	77
• LIST OF HOLDING REGISTERS - MODBUS PROTOCOL.....	78
• TABLE A - STATUS REGISTER CODING .....	82
• TABLE B - KEYBOARD LOCK CODING .....	82
• TABLE C - INPUT/OUTPUT CODING .....	82
• TABLE D - VALUE CODING FOR DIVISION AND DECIMALS .....	82

- TABLE E - BALANCING STATUS CODING..... 82
- TABLE F - COMMAND REGISTER / DATA REGISTER CODING ..... 83
- NUMBER OF LOAD CELLS ..... 85
- OUTPUT RATE OF THE CONVERTER ..... 86
- EXAMPLES ..... 86
- VTW CONNECT - USING SERIAL APPLICATIONS VIA USB PORT ..... 87**
- FIELDBUS PROTOCOL ..... 88
- INPUT DATA AREA..... 88
- READING EXAMPLE ..... 89
- OUTPUT DATA AREA ..... 90
- WRITING EXAMPLES ..... 91
- TROUBLESHOOTING GUIDE ..... 93**

## PRECAUTIONS

**READ** this manual **BEFORE** using or servicing the device.

**FOLLOW** these instructions carefully.

**KEEP** this manual for future reference.



### WARNING

*The purpose of this manual is to provide the operator with essential guidelines for the installation and proper use of the device through explanatory texts and illustrations.*

*Installation, maintenance, and repair must only be carried out by qualified personnel who have read and understood this manual. "Qualified personnel" refers to individuals who, due to their training and professional experience, have been expressly authorized by the Safety Manager of the system to perform the installation.*

*Power the device with a voltage that falls within the limits specified in the technical specifications.*

*It is the user's responsibility to ensure that the installation complies with current regulations.*

*Any attempt to disassemble or modify the device without explicit authorization will void the warranty and release Pavone Sistemi from any liability.*

*The installation and maintenance of this device must only be performed by qualified personnel.*

*Exercise caution when performing inspections, tests, and adjustments while the device is powered on.*

*Make electrical connections only when the power supply is disconnected.*

*Failure to observe these precautions may result in hazards.*

**DO NOT** allow untrained personnel to operate, clean, inspect, repair, or tamper with this device.

# INTRODUCTION

WT68 is a weight transmitter, the result of the latest and most advanced technology for weighing and force measurement systems using load cells. The device allows for the separate display of up to a maximum of 8 channels.

The instrument converts the load cells' mV signal into a high-resolution (24-bit) digital signal for each individual cell. The sum of the individual channels thus provides a more precise measurement of the acquired weight.

The transmitter can be integrated as a slave in different types of networks through various serial communication or Fieldbus protocols.

## The advantages of transmitting the individual weight values of the load cells include:

1. Independent display of the mV/V output and the weight value of each individual cell.
2. Monitoring of all load cells and alarm generation for excessive signal drifts, connection failures, cell faults, or unbalanced weight distribution.
3. Emulative control allows the weighing system to continue operating even in the event of a failure in a single load cell, until repair or replacement is performed.
4. The equalization function automatically compensates for differences between the weight values detected by the load cells during the system startup.
5. A special algorithm enables angle equalization of the scale with just one pass of the reference weight, instead of the multiple passes required by traditional calibration methods.

## AVAILABLE VERSIONS:

- **WT68:** Weight transmitter with serial output RS232, USB, RS485, and Peak function. Supported protocols include Modbus RTU, continuous, slave, and on request. Features two programmable setpoints, two inputs, and Peak function.
- **WT68/A:** Version with analog output.
- **WT68/PROFINET:** Weight transmitter with serial output RS232, USB, and PROFINET.
- **WT68/ETHERNET IP:** Weight transmitter with serial output RS232, USB, and ETHERNET IP.
- **WT68/ETHERCAT:** Weight transmitter with serial output RS232, USB, and ETHERCAT.
- **WT68/ETHERNET:** Weight transmitter with serial output RS232, USB, and ETHERNET.
- **WT68/PROFIBUS:** Weight transmitter with serial output RS232, USB, and PROFIBUS.
- **WT68/CANOPEN:** Weight transmitter with serial output RS232, USB, and CANOPEN.

## TECHNICAL CHARACTERISTICS

CHARACTERISTIC	SPECIFICATIONS
Power Supply	12÷24 VDC ± 15%
Maximum Power Consumption	4 W
Insulation	Class II
Installation Category	Cat. II
Operating Temperature	-10°C ÷ +50°C (14 °F ÷ 122 °F) (max 85% humidity, non-condensing)
Storage Temperature	-20°C ÷ +70°C (-4 °F ÷ 158 °F)
Weight Display	128 x 64 pixel graphic LCD
Keyboard	4 membrane keys
Overall Dimensions	100 x 75 x 110 mm (3.94 x 2.95 x 4.33 in) (W x H x D)
Mounting	On DIN rail or OMEGA bar support
Enclosure Material	Self-extinguishing Noryl (UL 94 V1)
Connections	Removable screw terminals, 3.81 mm (0.15 in) pitch
Load Cell Power Supply	5 VDC (max 16 load cells of 350 Ω in parallel), short-circuit protected
Input Sensitivity	0.02 μV min.
Linearity	< 0.01% of full scale
Temperature Drift	< 0.001% of full scale / °C
Internal Resolution	24 bit
Displayed Weight Resolution	Up to 999,999 divisions over the usable range
Measurement Range	-3.9 mV/V to +3.9 mV/V
Weight Acquisition Frequency	12.5 Hz ÷ 300 Hz
Digital Filter	Selectable 0.25 ÷ 25 Hz (up to 250 Hz manually)
Decimal Places for Weight	0 to 4 decimal places
Zero and Full-Scale Calibration	Automatic (theoretical) or manually via keyboard
Logical Inputs	2 opto-isolated at 24 VDC PNP (external power supply)
Logical Outputs	4 relays max 48 VDC/AC, 2 A (2 relays when Analog Output is present)
Serial Ports (x2)	RS232C and RS485
Maximum Cable Length	15m (49.21 ft) (RS232C) and 1000m (3280.84 ft) (RS485)
Serial Protocols	ASCII, Modbus RTU
Baud Rate	Selectable: 1200, 2400, 4800, 9600, 19200, 38400, 57600, 115200
USB Device Port	USB 2.0 compliant; speed up to 12 Mbps
Analog Output (Optional)	Opto-isolated, 16 Bit
Analog Output Voltage	0÷5/10 V (R min 10 KΩ)
Analog Output Current	0/4÷20 mA (R max 300 Ω)
Analog Output Calibration	Via keyboard
Analog Output Linearity	< 0.02% FS
Analog Output Thermal Drift	0.001% FS / °C
Microcontroller	32-bit ARM Cortex M0+, 256KB Flash, USB on-board reprogrammable
Data Memory	64 KBYTES EXPANDABLE UP TO 1024 KBYTES
Fieldbus (alternative to RS485)	PROFINET, ETHERNET IP, ETHERCAT, ETHERNET, PROFIBUS, CANOPEN
Compliance Standards	EN61000-6-2, EN61000-6-3, EN61010-1

# INSTALLATION

## GENERAL

The WT68 consists of a motherboard, to which available options are added, housed in a plastic enclosure for 35 mm (1.38 in) DIN rail mounting.



***The WT68 should not be submerged in water, exposed to water jets, or cleaned or washed with solvents.***

***Do not expose it to heat sources or direct sunlight.***

***Do not install the device near power equipment (motors, inverters, contactors, etc.) or any equipment that does not comply with CE standards for electromagnetic compatibility.***

The connection cable for the load cells must have a maximum length of 140 m/mm<sup>2</sup> (355.600 ft/in<sup>2</sup>).

The RS232 serial line should have a maximum length of 15 meters (49.21 ft) (EIA RS-232-C standards).

The warnings for the connection of each peripheral device must be followed.

## DOVERALL DIMENSIONS

Bottom View:

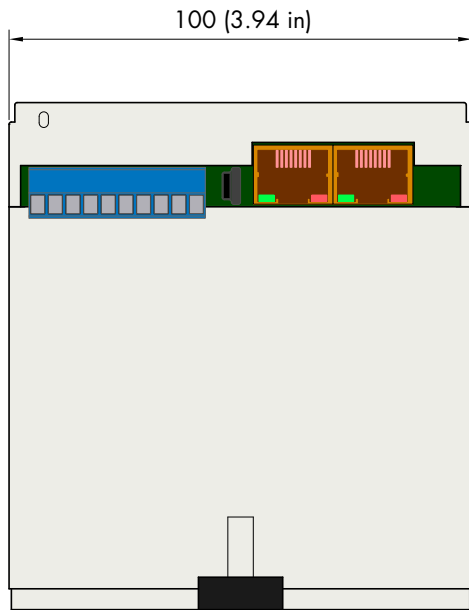

Side View:

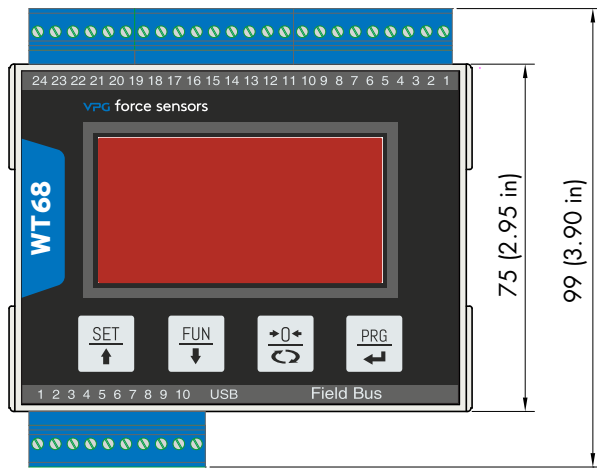
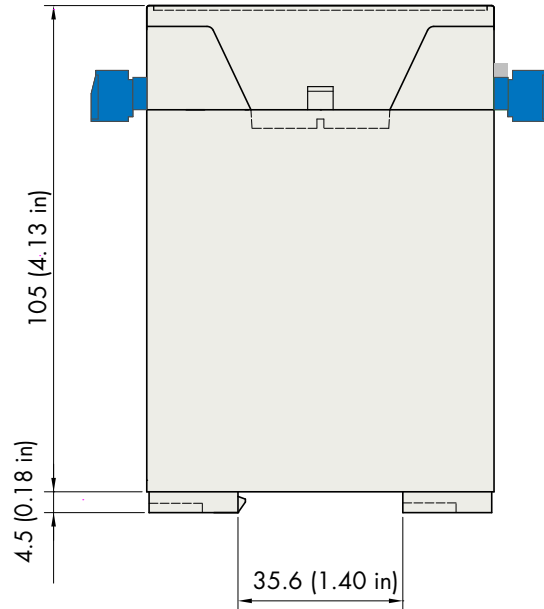

Front View:

### ELECTRICAL INSTALLATION



The WT68 transmitter uses removable screw terminals with a 3.81 mm (0.15 in) pitch for electrical connections. The load cell cable must be shielded and routed away from power cables to avoid electromagnetic interference.

## POWER SUPPLY OF THE DEVICE

The device is powered through terminals 9 and 10. The power cable should be routed separately from other cables.

The device is in Class II insulation (double insulation), and no ground terminal is required.

Power Supply Voltage: **12÷24 VDC ±15%, max 4W**

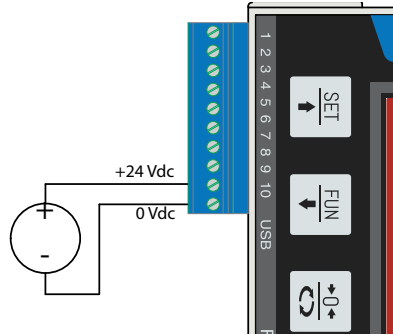

## LOAD CELL CONNECTIONS

The load cell cable should not be routed with other cables but should follow its own path.

The device, in its optional configuration, has 8 channels and can drive up to 16 cells of 350 ohms. Therefore, 2 load cells of 350 ohms in parallel can be connected to each of the 8 channels. The load cell power supply is 5 VDC and is protected against temporary short circuits.

The device's measurement range is designed for use with load cells having sensitivity up to 3.9 mV/V.

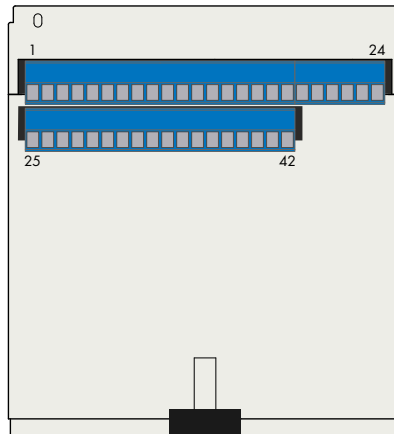

## LOAD CELL CONNECTION TABLE:

UPPER terminal block			LOWER terminal block		
1	LC1	+EXC	25	LC5	+EXC
2		+Signal	26		+Signal
3		-Signal	27		-Signal
4		-EXC / Screen	28		-EXC / Screen
5	LC2	+EXC	29	LC6	+EXC
6		+Signal	30		+Signal
7		-Signal	31		-Signal
8		-EXC / Screen	32		-EXC / Screen
9	+Sense		33	+Sense	
10	-Sense		34	-Sense	
11	LC3	+EXC	35	LC7	+EXC
12		+Signal	36		+Signal
13		-Signal	37		-Signal
14		-EXC / Screen	38		-EXC / Screen
15	LC4	+EXC	39	LC8	+EXC
16		+Signal	40		+Signal
17		-Signal	41		-Signal
18		-EXC / Screen	42		-EXC / Screen

*The Sense terminals are common for all load cells. In the case of 4-wire load cells, create a jumper between +EXC and +Sense, and between -EXC and -Sense. Connect the load cell cable shield to the -EXC terminal.*

## LOGIC INPUTS

The two logic inputs are opto-isolated.

The function of the two inputs can be selected from the Setup menu.

Activation of the two functions is achieved by applying an external 24 VDC power supply to the corresponding terminals, as shown in the adjacent figure.



**The connection cable for the logic input must not be routed together with power cables. Minimize the length of the connection cables.**

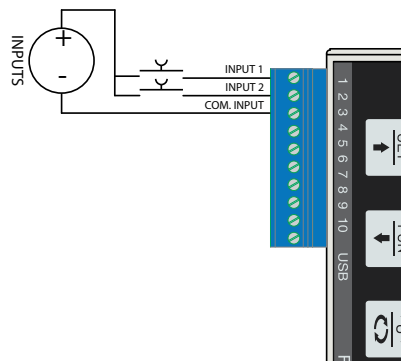

## LOGIC OUTPUTS

The four relay outputs have normally open contacts.

Each contact has a maximum rating of 48 VAC/DC, 2 A.



*The connection cable for the outputs must not be routed together with power cables.  
The connection should be kept as short as possible..*

The installation environment may be exposed to strong magnetic fields and electrical disturbances caused by nearby machinery. Therefore, it is essential to implement appropriate protective measures to prevent interference with the sensitive signals of a precision electronic device. Recommended precautions include:

**Filters on contactors**

**Diodes on 24 VDC relays**

**Other standard noise suppression techniques)**

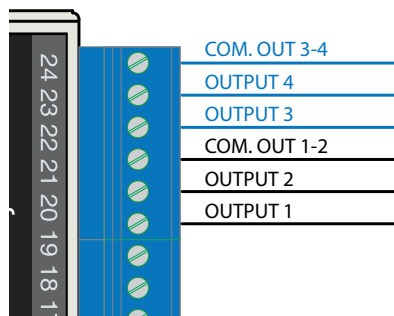

## SERIAL COMMUNICATION

### RS232

The RS232 serial port is typically used for connections to a PC, printer, or repeaters.

To establish the serial connection, use a suitable shielded cable, ensuring that the shield is grounded at only one end.



*The cable must not be routed together with power cables.  
The maximum length is 15 meters (49.21 ft) (according to EIA RS-232-C standards).  
For longer distances, the optional RS485 interface should be used.*

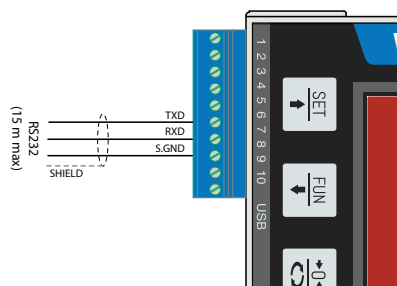

## RS485

The RS485 serial connection is a 2-wire type and allows up to 32 devices to be connected to a single MASTER unit (such as a PC, PLC, etc.).

For proper operation, use a twisted and shielded cable, ensuring that the shield is grounded at only one end.



**The cable must not be routed together with power cables.**

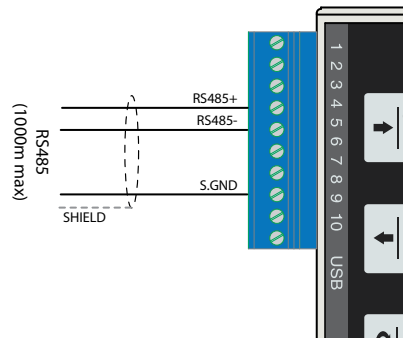

## ANALOG OUTPUT (OPTIONAL)

The transmitter provides an analog output in either current or voltage.

**Voltage output:** Range 0 to 10 V or 0 to 5 V, with a minimum load of 10 K $\Omega$ .

**Current output:** Range 0 to 20 mA or 4 to 20 mA, with a maximum load of 300  $\Omega$ .

To ensure proper connection, use a suitable shielded cable, making sure to ground the shield at only one end.



**WARNING: Do not connect the analog output to active devices.**

**Analog transmission can be sensitive to electromagnetic interference, so it is recommended that:**

- **The cables be kept as short as possible.**
- **The cables follow a dedicated routing path, separate from power cables.**

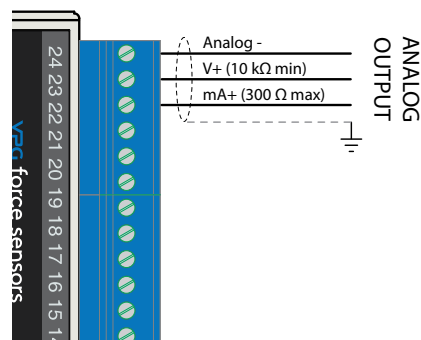

### USB DEVICE (SPECIFICATION 2.0 COMPLIANT; FULL-SPEED 12 MBPS)

Use this communication port to directly interface a PC via a USB port.

- Use a standard USB cable for the connection.
- To connect the device via the USB device port, the appropriate driver must be installed on the PC, according to the operating system used.
- Follow the specific installation instructions for proper setup.

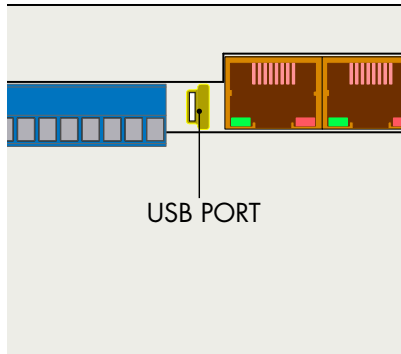

### OPTIONAL FIELDBUS CONNECTIONS

As an alternative to the RS485 serial port, some of the most widely used fieldbus protocols are available. Only one fieldbus can be used, and it must be specified at the time of order.

### ETHERNET CONNECTION

An **RJ45** connector for Ethernet network is located on the lower left side of the device.

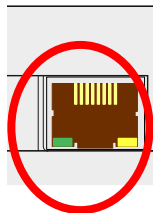

### FEATURES:

FEATURE	SPECIFICATION
Transmission speed	10 Mbps
Compatible network	10/100/1000 Base-T
Ethernet protocols	TCP, Modbus/TCP, UDP, IP, ICMP, ARP
Communication mode	TCP server
LED indicators	(2) Ethernet link status and communication/diagnostics
Buffer size	256 bytes
Connection timeout	Min 30 seconds - Max 90 seconds
Link timeout (cable unplugged)	30 seconds

## ETHERNET CONNECTION: CABLE TYPES AND CONNECTION METHODS

To connect to the **MASTER**, use a twisted pair Ethernet cable with an RJ45 connector.

**The maximum cable length depends on the cable type:**

A standard shielded **Cat5** cable can reach a maximum length of approximately **180 meters (590.55 ft)**.

PIN	DESCRIPTION
1	TX+
2	TX-
3	RX+
4	
5	
6	RX-
7	
8	

It is possible to connect the Ethernet communication port directly to a PC, without using additional network devices (such as a router, switch, hub, or LAN bridge). However, this requires a special RJ45 cable, known as a “**crossover**” cable.

- **Standard Ethernet** cables are typically “straight-through” and are used to connect devices to network equipment such as routers or hubs.
- **Crossover cables** are required to connect two PCs directly or a device to a PC without an intermediary network device.

Many modern network **interface cards (NICs)** feature auto-sensing technology, which can automatically detect the type of cable and connection, allowing direct PC-to-PC connections even with standard (non-crossover) Ethernet cables.

On the side, you will find diagrams illustrating the wiring schemes for both cable types and their respective connection configurations.

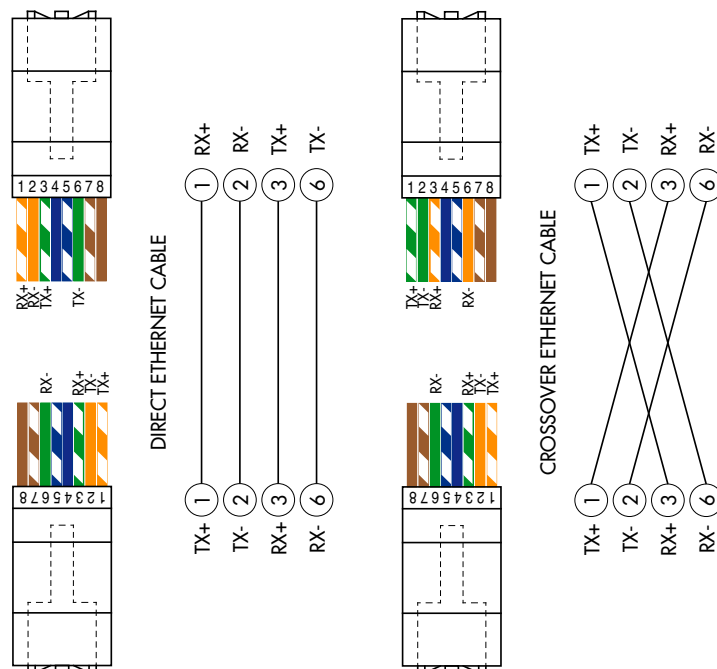

## ETHERNET/IP CONNECTION

EtherNet/IP is a real-time industrial protocol based on the Ethernet network.

The device features two RJ45 connectors to allow multiple instruments to be connected within the same network.

Refer to the previous description for connection guidelines and important warnings..

### Features:

FEATURE	SPECIFICATION
Transmission Speed	10 and 100 Mbit operation
Duplex Mode	Full and Half Duplex
Communication Protocol	Modbus-TCP server
I/O Fieldbus	Up to 128 bytes in each direction

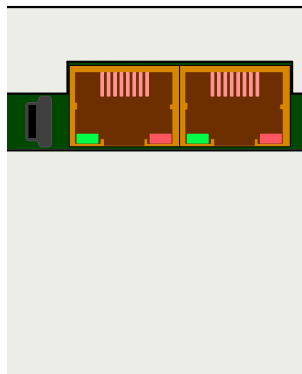

## PROFINET CONNECTION

There are two RJ45 connectors to allow multiple instruments to be connected within the same network.

Refer to the previous page for connection guidelines and important warnings.

### Features:

FEATURE	SPECIFICATION
PROFINET Communication	IO Real Time (RT)
Communication Protocol	Modbus-TCP server
I/O Fieldbus	Up to 128 bytes in each direction

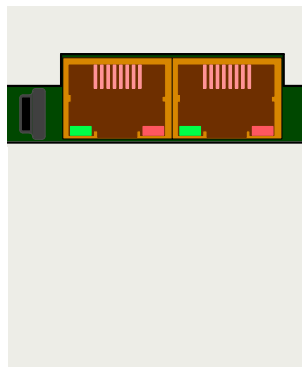

## ETHERCAT CONNECTION

EtherCAT is a real-time industrial protocol based on the Ethernet network.

The EtherCAT protocol requires that the RJ45 connectors function as **IN** and **OUT** ports.

When connecting multiple WT68 devices in series:

The **MASTER** must be connected to the **IN** connector of the first WT68.

The **OUT** connector of the first device should be connected to the **IN** connector of the next device, and so on.

*Refer to the previous page for connection guidelines and important warnings.*

## MAC ADDRESS IN DEVICES WITH INDUSTRIAL ETHERNET FIELDBUS

Devices equipped with Hilscher modules supporting Industrial Ethernet protocols (Profinet, Ethernet/IP, EtherCAT, etc.) have a **label** located beneath the **connectors**, as shown in the figure.

**This label includes:**

- The MAC Address of the module (red box)
- A module identification number (blue box)
- A QR code containing the MAC Address

The **QR code** can be scanned using a smartphone app (e.g., "QR Code Reader" available on Google Play Store).



## PROFIBUS CONNECTION

Pin	Signal	Description
1	-	-
2	-	-
3	B line	+RxD / +TxD, RS485 level
4	RTS	Request to send
5	GND	Ground (isolated)
6	+5V Bus Output	+5V termination (isolated)
7	-	-
8	A line	-RxD / -TxD, RS485 level
9	-	-
<b>Housing</b>	Cable Shield	Internally connected to the protective ground according to PROFIBUS specifications

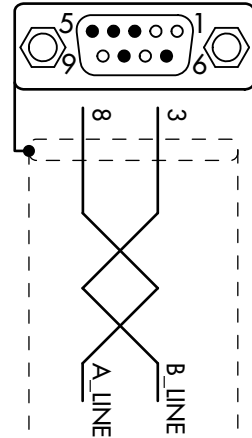

For the connection to the **PROFIBUS MASTER**, use a standard **PROFIBUS** cable.

- The **typical impedance** of the cable should be between 100 and 130 Ohms ( $f > 100$  kHz).
- The **cable capacitance** (measured between conductors) should be less than 60 pF/meter (18.29 pF/ft).
- The **minimum conductor** cross-section should be at least 0.22 mm<sup>2</sup> (0.000341 in<sup>2</sup>).

In a **PROFIBUS-DP** network, both **Type A** and **Type B** cables can be used, depending on the performance requirements.

The following table summarizes the characteristics of the cable to be used:

Characteristic	Type A Cable	Type B Cable
<b>Impedance</b>	135 to 165 $\Omega$ ( $f = 3\text{--}20$ MHz)	100 to 300 $\Omega$ ( $f > 100$ kHz)
<b>Capacitance</b>	< 30 pF/m (9.14 pF/ft)	< 60 pF/m (18.29 pF/ft)
<b>Resistance</b>	< 110 $\Omega$ /km	-
<b>Conductor cross-section</b>	> 0.34 mm <sup>2</sup> (0.000527 in <sup>2</sup> )	> 0.22 mm <sup>2</sup> (0.000341 in <sup>2</sup> )

The following table shows the maximum line length for **Type A** and **Type B** cables, depending on the required communication speed:

Baud rate (kbit/s)	9.6	19.2	187.5	500	1500	3000	6000	12000
<b>Max Length (m/ft) Type A Cable</b>	1200 / 3937	1200 / 3937	1000 / 3281	400 / 1312	200 / 656	100 / 328	100 / 328	100 / 328
<b>Max Length (m/ft) Type B Cable</b>	1200 / 3937	1200 / 3937	600 / 1969	200 / 656	-	-	-	-

For **reliable Fieldbus operation**, a line termination should be used at both ends of the network.

If multiple WT68 devices are connected, the line termination should be applied to only one device.

For **card configuration**, the **GSD** file (hms\_1810.gsd) is available and must be installed on the master.

## FRONT PANEL OF THE DEVICE

The WT68 transmitter features a **128 x 64** pixel graphic LCD display, which shows all weight information and status indications for Inputs and Outputs.

Additionally, depending on the programming procedures, the display is used for:

- **Programming parameters** to be stored in memory.
- **Displaying messages** indicating the type of operation in progress, assisting the operator in managing and configuring the device.

The setup parameters are **easily accessible and adjustable** using the front buttons, which allow the user to **select, modify, confirm**, and save new settings.

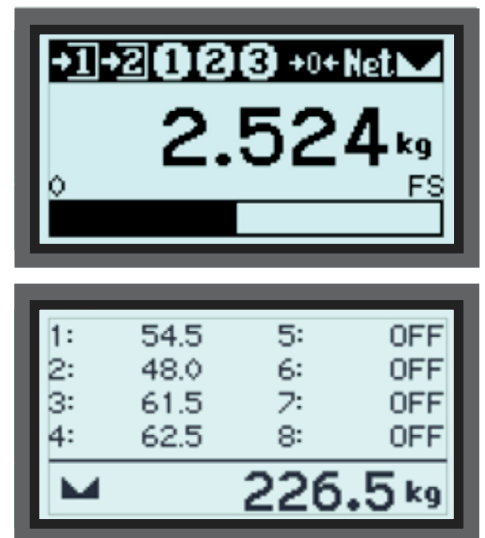
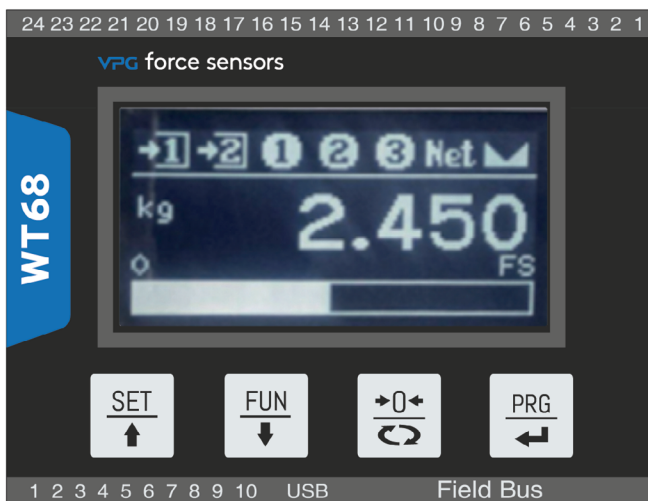

### STAND-BY FUNCTION

The display can enter **stand-by mode**, during which:

- **The display brightness is reduced.**
- **The keyboard is locked.**

All other instrument functions remain active and operational.

*Refer to the relevant section for activation/deactivation of stand-by mode.*

## KEYPAD USAGE

The device is programmed and controlled using a keypad with **4 buttons**, each having a dual function. The selection of a button's function is automatically determined by the device based on the current operation.



**In general, menu navigation is managed as follows:**

















↑ (Up) and ↓ (Down) keys: Scroll through menu items.





Enter (↵) key: Access the corresponding submenu or programmable parameter.



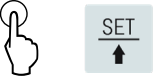

NO (↶↷) key: Exit the menu or return to the previous level.





Pressing the  key always leads to the previous menu.

Symbol	Description
	Short press on a single key. The buzzer emits a short beep.
	Long press on a single key. The buzzer emits a short beep at the press and a long beep after <b>2 seconds</b> .

BUTTON	FUNCTIONS DURING WEIGHT DISPLAY
 	Access the programming menu for setpoint values.
 	Select display mode (gross weight, net weight).
 	Toggle display views (Total / Individual cells / Current load percentage / Load cell signal).
 	Send weight string via serial line.
  + 	(Press for 3 sec) access the setup menu.
 	Perform semi-automatic zeroing.
  + 	Enter or exit stand-by mode.

BUTTON	FUNCTIONS DURING MENU NAVIGATION
	Select the previous menu.
	Select the next menu.
	Exit the programming menu or return to the previous level.
	Access the corresponding submenu, enter parameter programming, or confirm the selected parameter.

BUTTON	BUTTON   FUNCTION DURING NUMERIC VALUE INPUT
	Increase the value of the selected digit.
	Decrease the value of the selected digit.
	Select the next digit / Exit without saving changes.
	Confirm and save the entered value.
	Reset all digits to zero.

BUTTON	FUNCTIONS DURING SUGGESTED VALUE SELECTION
	Select the next value.
	Select the previous value.
	Confirm and save the displayed value.
	Exit without saving changes.

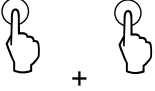

## KEYBOARD LOCK/UNLOCK FUNCTIONS

OPERATION	DESCRIPTION
	<b>Keyboard Lock</b> - The keys are disabled until unlocked. The display enters low power mode. Turning the device off and on will automatically unlock the keyboard.
	<b>Keyboard Unlock</b> - The keys are re-enabled, and the display brightness returns to standard.

## EXIT FROM THE CONFIGURATION MENU

Press the button  to return to the **main menu**.

Press the button again  the message "**SAVE?**" appears

Press the button  to **save** and **display** the weight, or press the button  to return to the **setup menu**.

## DISPLAY INFORMATION

Upon startup, the device performs a display test, followed by the display of key device information, including:

- Software version
- Number of programmed channels
- Installed Fieldbus protocols
- Codes to provide for technical support requests

**When no programming procedure is active, the display shows:**

- **Top section:** Status of inputs, outputs, weight, and stability.
- **Center section:** Weight value along with the unit of measurement.
- **Bottom section:** A bar graph indicating the current weight relative to the full-scale value.













### ERROR INDICATIONS

Any system error messages are displayed in the center of the screen, replacing the weight value.

## OPERATIONAL FUNCTIONS

After calibration, on subsequent startups, the display shows the current weight.

Below are the possible keyboard operations that can be performed while the instrument displays the weight.

BUTTON	OPERATION	FUNCTION
		Toggle between Gross Weight and Net Weight display.
		Show peak value; hold the button to exit the function.
		Perform Auto-Tare when viewing <b>Net Weight</b> .
		Perform Semi-Automatic Zero when viewing <b>Gross Weight</b> .
		Send a string via serial line (only for on-demand protocol) or print (if printer protocol is selected) on RS232.
		Access Set-Point programming function.
 + 		Access the Programming Menu.

### GROSS WEIGHT / NET WEIGHT DISPLAY

Press the button  to switch between **Gross Weight** and **Net Weight** display.

The displayed value is indicated by the **NET LED (ON: Net Weight)**.

If no tare is applied, **Net Weight = Gross Weight**.

In case of a negative weight, the "-" (minus) sign appears before the most significant digit.

### WEIGHT ZEROING AND AUTO-TARE

Both functions are performed using the button .

In "**Net**" mode (NET LED ON): The button  executes the **Auto-Tare** function.

In "**Gross**" mode (NET LED OFF): The button  executes the **Gross Weight Zeroing** function.

## ZEROING FUNCTION

The gross weight zeroing command is used to correct small zero shifts in the weighing system during normal operation. These zero drifts are usually caused by thermal variations or the accumulation of material residues on the weighing system over time.

To execute the zeroing command, the instrument must be in **Gross Weight mode (NET indicator OFF)**, and the weight deviation from the initial zero calibration must not exceed the number of divisions set in the "**O BAND**" parameter (within the **PARAM** menu).

**The gross weight zeroing command will not be executed if any of the following conditions occur:**

- **Unstable Weight:** If the stability control is enabled, zeroing will only be executed if the weight stabilizes within **3 seconds**. If stability control is disabled (**MOTION** parameter = 0), zeroing is performed regardless of weight stability.
- **Weight Outside the Zero Band:** If the gross weight (positive or negative) exceeds the "**O BAND**" parameter and no autozero threshold is programmed, zeroing will not be executed.

The zero obtained through the gross weight zeroing operation is stored in memory even after the instrument is turned off. Zeroing can be performed multiple times, but each zeroed weight division is cumulative. If the total exceeds the "**O BAND**" limit, further zeroing is not possible, and a Zero Calibration must be performed.

If the **AUTO 0** parameter is set, it reduces or even eliminates (if **AUTO 0 > O BAND**) the zeroing range of the manual zeroing command.

## AUTO-TARE

**The execution of the Auto-Tare function is possible under the following conditions:**

- The instrument is in **Net Weight mode (NET indicator ON)**.
- The gross weight is positive.
- The gross weight does not exceed the maximum capacity.
- The weight is stable.

**If the weight is unstable, two cases must be distinguished:**

- Weight stability control is enabled (**MOTION** parameter  $\neq$  0): The command executed while the weight is unstable will take effect only if the weight stabilizes within 3 seconds after the command is given.
- Weight stability control is disabled (**MOTION** parameter = 0): The command takes effect immediately, even if the weight is unstable.

**(\*) The operating modes of the MOTION parameter are described in the corresponding section.**

**The Auto-Tare value is stored in memory, even after the instrument is turned off.**

## TEST FUNCTIONS – RS232 AND RS485

The test consists of transmitting the received string from the corresponding serial line (echo) and displaying:

- The number of received strings.
- The number of characters received in the last string.

00C= 00

## TEST FUNCTIONS - ANALOG OUTPUT TEST

Once inside the test function, the following message will appear:

**0%**, where **0** indicates the output value (current or voltage, depending on the selected setting) expressed as a percentage of the full scale.

This value can be changed from **0%** to **100%**, in **10%** increments, by pressing the **SET** and **FUN** buttons. Press the **ZERO** button to exit the function.

## TEST FUNCTIONS - INPUT/OUTPUT TEST

Once inside the **IN/OUT** test function, the following message will appear:

**IN-00 OUT-0000**, where **00** depends on the state of the logic inputs, as shown in the corresponding table:

VALUE	MEANING
00	No input active
01	Input 1 active
10	Input 2 active
11	Inputs 1 and 2 active

In the same menu, it is possible to enable or disable the outputs by pressing the four front buttons, each of which activates or deactivates a single output.

<b>SET</b>	<b>FUN</b>	<b>ZERO</b>	<b>PRG</b>
<b>OUT1</b>	<b>OUT2</b>	<b>OUT3</b>	<b>OUT4</b>

Press and hold the **ZERO** button to exit the function.

## WEIGHT THRESHOLD PROGRAMMING

The set threshold values are compared with the weight to control the corresponding logic output.

The comparison criteria are defined in the setup procedure for logic **inputs/outputs** (refer to the corresponding section).

To access the Set Point settings, press the **SET** button while the weight is displayed.

MENU	MESSAGE	DESCRIPTION	TYPE	DEFAULT	RANGE	FIELDBUS INDEX
Setpoint	SETPOINT 1	Set value for Setpoint 1	Com.	0	0 ÷ Full Scale	201 (MSW) 202 (LSW)
	SETPOINT 2	Set value for Setpoint 2	Com.	0	0 ÷ Full Scale	203 (MSW) 204 (LSW)
	SETPOINT 3	Set value for Setpoint 3	Com.	0	0 ÷ Full Scale	205 (MSW) 206 (LSW)
	SETPOINT 4	Set value for Setpoint 4	Com.	0	0 ÷ Full Scale	207 (MSW) 208 (LSW)

The set threshold values are compared with the weight to control the corresponding logic output.

The comparison criteria are defined in the threshold setup procedure.

When the weight is not detectable or out of range, all outputs are deactivated (open or closed contact, depending on the **MODE** setting; see the relevant chapter).

During the threshold setting phase, both outputs remain deactivated. If the stored threshold value is **0**, the corresponding output is never activated, regardless of the selected threshold setup.

## WEIGHT ACQUISITION

The weight can be printed or sent via serial port/fieldbus (depending on the communication port settings) using the following methods:

- **Automatic mode** (if the serial communication protocol is set to "automatic").
- **Via the instrument's keypad** (by pressing the PRG button, if the serial communication protocol is set to "on demand").
- **From an external input** (if the serial communication protocol is set to "on demand" and the "on-demand data transmission" mode is enabled for at least one input).
- **Via the serial line** (if the serial communication protocol is set to "slave"), by sending the command to execute the weighing process.
- **Via fieldbus**, using the weighing execution command in the command register.

## CONDITIONS FOR WEIGHT ACQUISITION

- The **weight must be stable** (or stabilize within **3 seconds** after the command is given).
- Since the last acquisition, the weight must have changed by at least **20 divisions** (weight delta).
- The **gross weight** must be equal to or greater than the minimum weighing value (20 divisions) and less than the maximum capacity.
- The net weight must not be **zero**.

# CONFIGURATION

## GENERAL

All functions of the WT68 can be activated and modified by accessing a simple setup menu, represented on the next page.





All selected or activated settings remain stored in memory, even after the transmitter is turned off.



The WT68 is preconfigured with factory settings. The following pages list the default values for each parameter.





During the first field installation, some parameters must be adjusted to ensure accurate weight indication (theoretical calibration).

This operation can also be performed at the factory if the weighing system data is provided.

The setup menu settings can be modified using the front buttons or via the "VTW Connect" software utility, which is included with the device.

BUTTON	FUNCTIONS DURING MAIN MENU PROGRAMMING
	Select the next menu.
	Select the previous menu.
	Exit the programming menu or return to the previous level.
	Access the corresponding submenu, enter parameter programming, or confirm the selected parameter.

BUTTON	FUNCTIONS DURING SUGGESTED VALUE SELECTION
	Select the next value.
	Select the previous value.
	Confirm and save the displayed value.

BUTTON	FUNCTIONS DURING NUMERIC VALUE INPUT
	Increase the value of the blinking digit.
	Decrease the value of the blinking digit.
	Move to the next digit.
	Confirm and save the displayed value.

### PROCEDURE FOR MODIFYING AND ENTERING PARAMETERS:

To access the setup menu, press the **PRG** button, followed by the **SET** button, and hold both buttons simultaneously for **3 seconds**.

The following screen will appear:

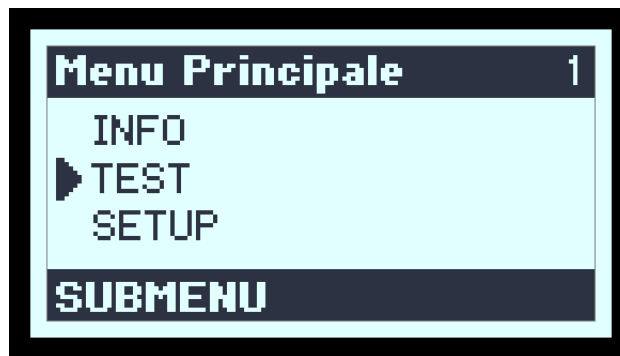

To access the **submenu**, confirm your selection by pressing the **PRG** button.

MESSAGE	NAME	DESCRIPTION
<b>INFO</b>	Information	Menu displaying parameters for identifying the instrument and its configuration.
<b>TEST</b>	Test	Menu for the hardware test procedures of the instrument.
<b>SETUP</b>	Setup	Menu for the programmable parameters that determine the operation of the instrument.

## INFO MENU

MENU	MESSAGE	NAME	DESCRIPTION	TYPE
INFO	VERSION	Firmware Code	Indicates the installed firmware code	Vis.
	FULL SCALE	Instrument Full Scale	Indicates the set full scale value of the instrument	Vis.
	N. OF CELLS	Enabled Cells Count	Indicates the number of enabled cells	
	FIELDBUS*	Fieldbus Type	Indicates the type of Fieldbus configured	Vis.
	ADDRESS*	Fieldbus Address	Indicates the Fieldbus address set. This entry is only visible in RS485 and PROFIBUS configurations	Vis.
	IP ADDRESS*	Fieldbus IP Address	Indicates the Fieldbus IP address set. This entry is only visible in PROFINET and ETHERNET/IP configurations	Vis.
	SUBNET.*	Fieldbus Subnet Mask	Indicates the Fieldbus subnet mask set. This entry is only visible in PROFINET and ETHERNET/IP configurations	Vis.
	ANALOG	Analog Output Configuration	Indicates the presence and type of the analog output (None - Unipolar - Bipolar)	Vis.
	MEMORY*	Optional Memory Configuration	Indicates the presence and type of optional memory (None - Alibi memory)	Vis.

*\* Parameters only available if the corresponding hardware option is installed.*

### In the case of a PROFINET fieldbus:

The IP address and **Subnet Mask** parameters are programmable from the **PLC** and are updated in this menu only when the device is powered on.

After modifying these parameters from the **PLC**, it is necessary to turn off and then turn on the instrument to display the correct values.

It is important to note that even if the **IP address** and **Subnet Mask** parameters are set temporarily, they will not be automatically updated in the instrument.

Moreover, when the instrument is powered off and then powered back on, these parameters will reset to **0.0.0.0**.

## TEST MENU

MENU	MESSAGE	NAME	DESCRIPTION	TYPE
TEST	LOAD CELL SIGNAL	Load Cell Signal	Displays the load cell signal in mV/V at the instrument's input.	Vis.
	WEIGHT X10	Resolution x10	Displays the weight with a resolution 10 times greater than the set value.	Vis.
	POWER SUPPLY	Power Supply	Displays the measured power supply voltage from the instrument.	Vis.
	IN/OUT	Test I/O	Performs an I/O test with simultaneous display of inputs and outputs (See specific description).	Test.
	RS 232	RS232 Test	Transmission and reception test (See specific description).	Test.
	RS 485	RS485 Test	Transmission and reception test (See specific description).	Test.
	ANALOG	Analog Output Test	Test procedure with manual activation of the output value (See specific description).	Test.
	MEMORY	Memory Test	Automatic test of the supplemental memory functionality (when present).	Test.

## SETUP MENU

MENU	SUBMENU	NAME
SETUP	CALIBRATION	Calibration Settings
	ANALOG (***)	Analog Output Settings
	CONNECTIONS	Serial and Fieldbus Port Settings
	IN/OUT	Logical Input and Output Settings
	PARAMETERS	Metrological Weighting Parameter Settings
	FILTER	Filter Settings
	FUNCTIONS	Functional Features Settings
	UPL/DOWNL	Upload / Download Function
	CLOCK (***)	Clock and Date Settings

**(\*\*) This menu entry is only displayed if the corresponding hardware option is present.**

**Upon exiting the setup menu, if any parameter modifications have been made, the "SAVE" message will appear, which must be confirmed by pressing the PRG button.**

## CONFIGURATION PARAMETERS

The following pages describe all the configurable parameters.

At the end of each parameter description, where applicable, the corresponding fieldbus address for the parameter is provided.

If the parameter is of a selectable type, the value to be entered in the register for the desired selection is indicated within [ ].

# CALIBRATION MENU

## NUMBER OF CELLS

### NUMBER OF CELLS [1101÷1102]

Number of load cells connected to the instrument

**Selectable values:**

1 ÷ 8

**Default:** 4

## UNIT

### UNIT OF MEASURE [1101÷1102]

Selection of the unit of measurement used, the desired unit can be set.

**Selectable values:**

g	kg	N	kN
---	----	---	----

**Default:** kg

## RESOLUTION

### DIVISION VALUE [1101÷1102]

Value of a single division, expressed in kg. The ratio between the system's capacity and the division value constitutes the system's resolution (number of divisions).

After modifying the division value, if the system capacity is not changed, the weight calibration is automatically corrected.

**Selectable values:**

0.0001	0.0002	0.0005
0.001	0.002	0.005
0.1	0.2	0.5
1	2	5
10	20	50

**Default:** 1

## CAPACITY

### LOAD CELL CAPACITY [1103-1104]

Defines the value corresponding to the sum of the nominal capacity of the load cells, expressed in the selected unit of measurement.

In systems with a single load cell and "N" fixed supports, enter the value of the load cell capacity for the total number of supports.

This value constitutes the full scale value of the weighing system.

After modifying the parameter value, the theoretical weight calibration is recalculated.

**Values:** 1 to 999999

**Default:** 0

## SENSITIVITY

### LOAD CELL SENSITIVITY [1105]

Set the sensitivity value for each load cell, in **mV/V**.

Values between **0.0** and **4 mV/V** are accepted. If no value is programmed, **2 mV/V** is assumed.

After modifying the sensitivity value, the theoretical weight calibration is performed.

**Values:** 0.1000 to 4.0000 mV/V

**Default:** 2.0000

## FULL SCALE

### WEIGHING SYSTEM CAPACITY [1301-1302]

Programming the useful (net) capacity of the weighing system.

**Values:** from 0 to Load Cell Capacity

**Default:** 0

## DEAD LOAD

### FIXED TARE WEIGHING SYSTEM [1106-1107]

Programming the value of the fixed tare for the weighing system.

**Values:** from 0 to Capacity Value

**Default:** 00000

## BALANCING

### BALANCING

This function is used to compensate for angles in platforms, avoiding the use of adjustment trimmers located in the junction boxes, so there is no weight difference when moving the same weight to the 4 corners of the platform.

**Values:** -

**Default:** -

## **CALIBRATION**

### **SELECTION OF CALIBRATION TYPE**

Select the type of calibration.

Upon confirmation, one of the following procedures will be initiated.

### **SAMPLE WEIGHT**

#### **DEAD WEIGHT CALIBRATION TYPE [501÷503]**

Zero and Full Scale calibration up to **5** linearization points using sample weights.

### **TABLE**

#### **TABLE CALIBRATION TYPE [1151÷1172]**

Allows for manual programming of up to 5 calibration points.

The values correspond to those determined by the sample weight linearization procedure.

This way, it is possible to copy the calibration values done with sample weights.

### **PARAMETERS DISPLAYED ONLY IN METRIC OPERATION MODE**

#### **G-CALIBRATION**

##### **GRAVITY AT CALIBRATION LOCATION [1108-1109]**

Programming the value of the local gravitational force at the location where calibration takes place.

**Values:** from 9,77000 to 9,84000

**Default:** 0

#### **G-USE**

##### **GRAVITY AT USE LOCATION [1110-1111]**

Programming the value of the gravitational force at the location where the instrument will be used.

**Values:** from 9,77000 to 9,84000

**Default:** 0

# LOAD CELL BALANCING

The procedure can be performed if at least 2 load cells are used; otherwise, the menu will not be active.

## AUTOMATIC PROCEDURE

To execute the automatic balancing procedure, you need a weight to be moved across the load cells that make up the weighing system.

Once in the menu, press the **PRG** button, and the message “**ZERO?**” will appear. Press **PRG** to confirm. The message “**00000**” will appear. Enter the value of the sample weight and press **PRG**.

At this point, the instrument will prompt you to load load cell number 1. Place the sample weight on load cell **1** and press **PRG**.

Proceed with the subsequent load cells until the last one.

If the loaded cell is incorrect or the procedure fails, the instrument will display an error.

In this case, correct the issue and try the procedure again.

Press **ZERO** to exit the procedure.

## BALANCING FACTOR

It is possible to manually modify the balancing factor of each individual load cell by accessing the appropriate menu and changing the value in the selected cell. The value can be set from **0.1000** to **9.9999** (the default value is **1.0000**).

## EXAMPLE OF CONFIGURATION/CALIBRATION

By setting the parameters listed above, the theoretical calibration of the Full Scale of the WT68 is performed.

This procedure must be completed with the zero calibration, which is described later. If there are no mechanical issues, this process ensures good system accuracy (maximum error <1% F.S.).

When the **RESOLUTION** selection is changed, the full-scale calibration is automatically recalculated. Selections that are incompatible with the calibration parameters or the calibration stored in memory are not accepted.

## EXAMPLE SCENARIO:

A tank needs to be weighed. The empty tank weighs **750 kg** and has a capacity of **1000 liters**. It contains a product with a specific weight of **1.3 kg/dm<sup>3</sup>**, and the displayed weight resolution must be **0.2 kg**.

## CONFIGURATION PROCESS:

Before proceeding, it is essential to ensure that the load cells are correctly connected to the unit and that the tank is empty. Once verified, parameter settings can be configured.

### The following load cells are used:

**3** load cells with a capacity of **1000 kg** each

Sensitivities of **2.0015**, **2.0008**, and **1.9998 mV/V**, respectively

**SET THE FOLLOWING VALUES IN THE CONFIGURATION PARAMETERS:**

Characteristic	Value
Number of load cells	3
Resolution	0.2 kg
Capacity	3000 kg
Sensitivity 1	2.0015 mV/V
Sensitivity 2	2.0008 mV/V
Sensitivity 3	1.9998 mV/V
Full Scale	1500 kg
Dead Load	0

Make sure that the value read in the **SIGNAL** parameter of the **TEST** menu corresponds to the tare weight of the system according to the following proportion:

$$3000:2.0015=750:X$$

Where **X** is the signal value expressed in **mV/V**, corresponding to the theoretical value of the empty tank weight.

The value should be approximately **0.5 mV/V**.

At this point, you can proceed with the calibration described in the next section or exit the configuration menu, saving the entered data.

The instrument should display the value corresponding to the empty tank weight (**e.g., 756.8**).

You can re-enter the configuration menu, enter the weight value read in the **DEAD WEIGHT** parameter, and input the value **756.8**.

Exit the configuration menu again, saving the data.

For greater accuracy, prepare standard weights or pre-weighed material on a certified scale and proceed with the calibration described in the next section.

# CALIBRATION WITH STANDARD WEIGHTS

The calibration method described here must be performed using standard weights and/or pre-weighed product on a certified reference scale.

Before proceeding with the full-scale calibration, always perform the zero calibration first.

During the calibration process, the display intermittently shows the weight along with the message **CAL**.

**WARNING:** *If the instrument is turned off without exiting the setup menu, the performed settings will not be saved.*

**Note:** *If, after calibration, the system shows linearity errors, check that the weighed structure is completely free from mechanical constraints.*

## ZERO CALIBRATION

Perform this operation with the scale unloaded (including the fixed tare) and with a stable weight reading.

### 1. ENSURE THE SYSTEM IS UNLOADED

- Make sure there is no weight on the scale except for the fixed tare.
- Wait for the weight reading to stabilize.

### 2. PERFORM THE ZERO CALIBRATION

- Press the **FUN** button.
- The displayed weight will reset to zero, and the display will show **CAL** alternating with **0**.

### 3. REPEAT IF NECESSARY

- This operation can be repeated multiple times to ensure proper zeroing.

### 4. EXIT THE CALIBRATION FUNCTION

- Press the **PRG** button to exit the **CAL** function.

## FULL-SCALE CALIBRATION

Before performing the operation, load the standard weight onto the scale and wait for stabilization; the display will show a weight value.

To adjust the displayed weight, press the **SET** button. The display will show all digits as **0**, with the leftmost digit flashing.

Use the arrow keys to enter the actual weight loaded on the scale, starting from the flashing digit.

Move to the next digit by pressing **PRG**. Confirming the last (rightmost) digit with the **PRG** button will apply the weight correction.

The display will show **SAVE**, followed by **CAL** alternating with the entered weight value.

If the entered value exceeds the instrument's resolution, the weight will not be accepted, and an error message will appear on the display for a few seconds.

The full-scale calibration procedure can always be repeated.

Press and hold the **PRG** button to return to the **CALIBRATION** menu.

## **LINEARIZATION PROCEDURE**

### **Linearization with Standard Weights (Long Press SET Button)**

- Up to **5** linearization points can be set on the positive scale.
- The linearization point number is displayed alternately with the current weight.

#### **1. Set the Standard Weight**

- Press the **SET** button to enter the value of the loaded and stabilized standard weight.
- Once confirmed, the display returns to the weight value.
- To set the next linearization point, press **SET** again.

#### **2. Conditions and Restrictions**

- If **0** is entered, the value will not be saved.
- A maximum of **5** linearization points can be stored, but fewer can be used if necessary.
- The calibration process can always be repeated.

#### **3. Weight Value Restrictions**

- Entered values must not exceed the full scale.
- Each value must be greater than the previous point.
- The weight must be stable for the value to be accepted.
- If the value is accepted, the next point is prompted; otherwise, the same point is re-requested.

#### **4. Automatic Reset of Linearization Points**

- Linearization points are automatically cleared whenever:
  - A theoretical calibration parameter is modified.
  - A full-scale calibration is performed.

#### **5. Exiting the Procedure**

- To end the procedure, press and hold the **PRG** button.

## TABLE CALIBRATION

This method allows manual programming of up to five calibration points, in addition to the zero value.

- The values correspond to those determined by the **linearization procedure** with standard weights.
- This feature enables the user to view the automatically determined values from the linearization process, as well as modify and program them according to predefined values.

SUBMENU	MESSAGE	NAME	DESCRIPTION	TYPE
TABLE	GET 0.	Zero Signal Acquisition	Function to acquire the signal in mV/V corresponding to the scale zero	Spc.
	0 SIGNAL	Zero Signal	Signal value in mV/V corresponding to the scale zero	Com.
	P1 VALUE	Weight Point 1	Weight value corresponding to the 1st calibration point	Com.
	P1 SIGNAL	Signal Point 1	Signal value in mV/V corresponding to the 1st calibration point	Com.
	P2 VALUE	Weight Point 2	Weight value corresponding to the 2nd calibration point	Com.
	P2 SIGNAL	Signal Point 2	Signal value in mV/V corresponding to the 2nd calibration point	Com.
	P3 VALUE	Weight Point 3	Weight value corresponding to the 3rd calibration point	Com.
	P3 SIGNAL	Signal Point 3	Signal value in mV/V corresponding to the 3rd calibration point	Com.
	P4 VALUE	Weight Point 4	Weight value corresponding to the 4th calibration point	Com.
	P4 SIGNAL	Signal Point 4	Signal value in mV/V corresponding to the 4th calibration point	Com.
	P5 VALUE	Weight Point 5	Weight value corresponding to the 5th calibration point	Com.
	P5 SIGNAL	Signal Point 5	Signal value in mV/V corresponding to the 5th calibration point	Com.

Values programmed as zero are not considered.

The data sheet calibration is automatically canceled when a new theoretical calibration or standard weight calibration is performed.



After executing the zero signal acquisition function, using the appropriate button , the signals in the table are recalculated.

For each signal value, an offset is added, derived from the difference between the newly acquired zero signal and the previous zero signal value.



## EXITING THE CALIBRATION MENU

To exit the **CALIBRATION** menu, press the button  repeatedly until the message **STORE?** appears.

To save the new calibration and exit the setup menu, press the **PRG** button.

It is possible to cancel the **zero** and **full-scale** calibrations:

Press  +  to cancel the **zero calibration**.

Press  +  to cancel the **full-scale calibration**.

# ANALOG OUTPUT PARAMETERS (OPTIONAL)

## RANGE

### RANGE – ANALOG OUTPUT RANGE [1506]

Selection of the analog output range.

#### Selectable values:

- $0 \div 10$  Vdc [0]
- $0 \div 5$  Vdc [1]
- $4 \div 20$  mA [2]
- $0 \div 20$  mA [3]

**Default:**  $0 \div 10$  Vdc

## MODE

### MODE – ANALOG OUTPUT OPERATING MODE [1505]

Selection of the value to be associated with the analog output, corresponding to net weight, gross weight, or peak value.

#### Selectable values:

- NET [0]
- GROSS [1]
- PEAK [2]

**Default:** NET

## ZERO

### ANALOG OUTPUT ZERO VALUE [1501-1502]

Analog value to be subtracted, referenced to the full-scale analog output.

## FULL SCALE

### FULL SCALE VALUE [1503-1504]

The weight corresponding to the full-scale analog output.

**Settable value:** from 0 to Capacity

**Default:** Capacity

## ZERO ADJUSTMENT

### ZERO OFFSET REGULATION

Measure the analog output value using a tester to perform the **zero (0)** calibration.

Use the arrow keys  and  to adjust the analog output.

Hold the button for a long press to enable rapid adjustment.

Press the button  to return to the menu.

## FS ADJUSTMENT

### FULL SCALE OFFSET REGULATION

Measure the analog output value using a tester to perform the full-scale (FS) calibration.

Use the **arrow keys**  and  to adjust the analog output.

Hold the button for a long press to enable rapid adjustment.

Press the button  to return to the **ANALOG** menu.

This procedure is available for user adjustment for each selectable range.

In the event of a complete setup memory reset, factory calibrations will be restored.

# CONNECTION PARAMETERS

This menu allows the configuration of communication parameters for RS232, RS485, and Fieldbus serial ports.

## RS232

### MODE

#### RS232 OUTPUT MODE

Selection of the value transmitted via the RS232 output.

#### Selectable values:

- NET
- GROSS
- PEAK

**Default:** NET

### DATA

#### RS232 DATA MODE

Selection of the data transmitted via the RS232 output.

#### Selectable values:

- SINGLE WEIGHT
- TOTAL WEIGHT

**Default:** TOTAL WEIGHT

### PROTOCOL

#### RS232 PROTOCOL

Defines the operating mode of the RS232 serial port.

#### Selectable values:

VALUE	DESCRIPTION
None	Serial communication disabled.
TX	Continuous transmission of the weight string, used for applications such as driving a weight repeater (see details in the relevant section).
On Demand	A weight string is transmitted when the operator presses the corresponding front panel button or via input. The command is accepted only if the weight is stable. Between two successive transmissions, the weight must change by at least 20 divisions.
Automatic	A weight string is automatically transmitted when the weight stabilizes at a value above the minimum weighing threshold (20 divisions).
Slave	ASCII protocol (see details in the relevant section).
Printer	A weight string is transmitted when the operator presses the corresponding front panel button or via input. The command is accepted only if the weight is stable. Between two successive transmissions, the weight must change by at least 20 divisions.
Default	None

## **SPEED**

### **RS232 BAUD RATE**

Defines the baud rate of the RS232 serial port.

The value must be set to match the baud rate of the PC, PLC, or remote display.

#### **Selectable values:**

- 1200 - 2400 - 4800 - 9600
- 19200 - 38400 - 57600 - 115200

**Default:** 9600

## **FRAME**

### **RS232 PROTOCOL**

Defines the frame type for RS232 communication.

For the **SLAVE** protocol, it is not possible to select a **7-bit** data format (E-7-1 and O-7-1).

#### **Selectable values:**

- n-8-1
- n-8-2
- E-7-2
- E-8-1
- o-7-2
- o-8-1

**Default:** n-8-1

## COM 2 PARAMETERS – WHEN RS485 IS AVAILABLE

### MODE

#### RS485 OUTPUT MODE

Selection of the value transmitted via the RS485 output.

**Selectable values:**

- NET
- GROSS
- PEAK

**Default:** NET

### DATI

#### RS485 DATA MODE

Selection of the data transmitted via the RS485 output.

**Selectable values:**

- SINGLE WEIGHT
- TOTAL WEIGHT

**Default:** TOTAL WEIGHT

### PROTOCOL

Defines the operating mode of the RS485 serial port.

**Selectable values:**

VALUE	DESCRIPTION
None	Serial communication disabled.
<b>TX</b> Continuous	Continuous transmission of the weight string, used for applications such as driving a weight repeater (see details in the relevant section).
<b>On Demand</b>	A weight string is transmitted when the operator presses the corresponding front panel button or via input. The command is accepted only if the weight is stable. Between two successive transmissions, the weight must change by at least 20 divisions.
<b>Automatic</b>	A weight string is automatically transmitted when the weight stabilizes at a value above the minimum weighing threshold (20 divisions).
<b>Slave</b>	ASCII protocol (see details in the relevant section).
<b>Modbus</b>	MODBUS RTU protocol (see details in the relevant section).
<b>Default</b>	None

## **SPEED**

### **RS485 BAUD RATE**

Defines the baud rate of the RS485 serial port.

The value must be set to match the baud rate of the PC, PLC, or remote display.

**Selectable values:**

- 1200 - 2400 - 4800 - 9600
- 19200 - 38400 - 57600 - 115200

**Default:** 9600

## **FRAME**

### **RS485 PROTOCOL**

Defines the frame type for RS485 communication.

For the **SLAVE** protocol, it is not possible to select a 7-bit data format (E-7-1 and O-7-1)

**Selectable values:**

- n-8-1
- n-8-2
- E-7-2
- E-8-1
- o-7-2
- o-8-1

**Default:** n-8-1

## **ADDRESS**

### **RS485 ADDRESS**

Defines the communication address of the RS485 serial port:

**Selectable values:** 1 to 32

**Default:** 1

## COM 2 PARAMETERS – WHEN PROFINET IS AVAILABLE

### ENABLE FIELDBUS

#### ENABLE FIELDBUS

Activates the **PROFINET** fieldbus communication. If set to **OFF**, error messages related to Fieldbus communication will not be displayed:

**Selectable values:**

- OFF
- ON

**Default:** OFF

### INPUT AREA

#### DIMENSIONE AREA INPUT

Defines the input area size for the fieldbus, measured in bytes.

**Selectable values:**

- 32, 64, 96, 128

**Default:** 128

### OUTPUT AREA

#### OUTPUT AREA – OUTPUT SIZE

Defines the output area size for the fieldbus, measured in bytes.

**Selectable values:**

- 32, 64, 96, 128

**Default:** 128

The XML configuration file required for **PLC** integration must be selected according to the configured option, which is specified on the device identification label.

The input and output area sizes set in the **PLC** (32, 64, 96, or 128 bytes) must match the input and output sizes selected in the device (parameters "INP.REG." and "OUT.REG.").

- **Option /PNet:**

*GSDML-V2.3-HILSCHER-NIC 50-RE PNS 32-20160122.xml*

- **Option /PNet X90:**

*GSDML-V2.35-HILSCHER-NETX 90-RE-PNS-32byte-M-20200507.xml*

The instruments are supplied with the "**PROFINET Name**" parameter not configured and the IP address set to **0.0.0.0**.

## COM 2 PARAMETERS – WHEN ETHERNET/IP IS AVAILABLE

### FIELDBUS ENABLE

#### ENABLE FIELDBUS

Activates the **Ethernet/IP** fieldbus communication.

If set to **OFF**, error messages related to Fieldbus communication will not be displayed:

**Selectable values:**

- OFF
- ON

**Default:** OFF

### IP

#### IP ADDRESS

Defines the IP address for the Ethernet/IP protocol.

**Selectable values:** from 0.0.0.0 to 255.255.255.255

**Default:** 0.0.0.0

#### SUBNET

#### SUBNET MASK

Defines the Subnet Mask for the Ethernet/IP protocol.

**Selectable values:** from 0.0.0.0 to 255.255.255.255

**Default:** 0.0.0.0

### INPUT AREA

#### INPUT AND OUTPUT AREA SIZE

Defines the input area size for the fieldbus, measured in bytes.

**Selectable values:**

- 32, 64, 96, 128

**Default:** 128

#### OUTPUT AREA

#### OUTPUT AREA – OUTPUT SIZE

Defines the output area size for the fieldbus, measured in bytes.

**Selectable values:**

- 32, 64, 96, 128

**Default:** 128

The EDS configuration file required for PLC integration must be selected according to the configured option, which is specified on the device identification label.

The input and output area sizes set in the PLC (default: 128 bytes for input, 128 bytes for output) must match the input and output sizes selected in the device (parameters "INP.REG." and "OUT.REG.").

**Option /E IP:**

- HILSCHER NIC 50-RE EIS V1.1.EDS

**Option /E IP X90:** (4 different configuration files provided)

- HILSCHER NETX90 EIS V5-32.EDS
- HILSCHER NETX90 EIS V5-64.EDS
- HILSCHER NETX90 EIS V5-96.EDS
- HILSCHER NETX90 EIS V5-128.EDS

In the PLC, the EDS file must match the input and output size selected in the instrument.

For example, if INP.REG.=128 and OUT.REG.=128 are set in the instrument, the PLC must import the file:

"HILSCHER NETX90 EIS V5-128.EDS".

## COM 2 PARAMETERS WHEN ETHERNET IS PRESENT

### MODE

#### ETHERNET OUTPUT MODE

Selection of the value transmitted on the ETHERNET port

**Selectable values:**

- NET
- GROSS
- PEAK

**Default:** NET

### PROTOCOL

#### ETHERNET COMMUNICATION PROTOCOL

Selection of the communication type for the Ethernet protocol.

**Selectable values:**

VALUE	DESCRIPTION
None	Serial communication disabled.
Contin	Continuous transmission of the weight string. This can be used, for example, to drive a weight repeater. See details in the relevant section.
on deM	When the operator presses the corresponding front key or via Input 2, a weight string is transmitted. The command is accepted if the weight is stable. Between two successive transmissions, the weight must change by at least 20 divisions.
Autom	A weight string is automatically transmitted when the weight stabilizes at a value above the minimum weighing threshold (20 divisions). Between two successive transmissions, the weight must change by at least 20 divisions.
Slave	ASCII protocol. See details in the relevant section.
Modbus	MODBUS TCP protocol.
Default	Slave

### IP

#### IP ADDRESS

IP address for the ETHERNET protocol.

**Values:** 0.0.0.0 to 255.255.255.255

**Default:** 192.168.0.201

## **SUBNET**

### **SUBNET MASK**

*Subnet mask for the ETHERNET protocol.*

**Values:** 0.0.0.0 to 255.255.255.255

**Default:** 255.255.255.0

### **GATEWAY**

#### **GATEWAY**

*Gateway for the ETHERNET protocol.*

**Values:** 0.0.0.0 to 255.255.255.255

**Default:** 192.168.0.1

### **PORT**

#### **PORT**

*Communication port for the ETHERNET protocol.*

**Values:** 1 to 65535

**Default:** 1800

## COM 2 PARAMETERS WHEN PROFIBUS IS PRESENT

### ENABLE FIELDBUS

#### FIELDBUS ACTIVATION

Enables the PROFIBUS fieldbus. If set to OFF, error messages related to Fieldbus communication will never be displayed.

**Selectable values:**

- OFF
- ON

**Default:** OFF

### ADDRESS

#### PROFIBUS ADDRESS

Sets the address used in the PROFIBUS protocol.

**Value range:** 1 to 126

**Default:** 01

### INPUT AREA

#### INPUT AREA SIZE

Size of the input area for the fieldbus (value expressed in bytes).

**Selectable values:** 32, 64, 96, 128

**Default:** 128

### OUTPUT AREA

#### OUTPUT AREA SIZE

Size of the output area for the fieldbus (value expressed in bytes).

**Selectable values:** 32, 64, 96, 128

**Default:** 128

The GSD configuration file, to be used for the PLC, must be selected from the two provided options based on the configured option specified on the instrument's identification label. The input and output area sizes set in the PLC must match the sizes selected on the instrument (parameters "INP.REG." and "OUT.REG.").

Option /P: *hms\_1810.gsd*

Option /P X90: *hil\_x90.gsd*

## COM 2 PARAMETERS WHEN ETHERCAT IS PRESENT

### ENABLE FIELDBUS

#### FIELDBUS ACTIVATION

Enables the ETHERCAT fieldbus. If set to OFF, error messages related to Fieldbus communication will never be displayed.

**Selectable values:**

- OFF
- ON

**Default:** OFF

### INPUT AREA

#### INPUT AREA SIZE

Size of the input area for the fieldbus (value expressed in bytes).

**Selectable values:**

- 32, 64, 96, 128

**Default:** 128

### OUTPUT AREA

#### OUTPUT AREA SIZE

Size of the output area for the fieldbus (value expressed in bytes).

**Selectable values:**

- 32, 64, 96, 128

**Default:** 128

The XML configuration file to be used for the PLC must be selected based on the configured option, specified on the instrument's identification label. Devices must be connected in a ring topology (as per EtherCAT specifications). Refer to the installation manual for details on using the INPUT and OUTPUT ports.

### **Option /ECat**

Four different configuration files are provided:

Hilscher NIC 50-RE ECS V2.2 32 Byte.xml

Hilscher NIC 50-RE ECS V2.2 64 Byte.xml

Hilscher NIC 50-RE ECS V2.2 96 Byte.xml

Hilscher NIC 50-RE ECS V2.2 128 Byte.xml

### **Option /ECat X90**

Four different configuration files are provided:

Hilscher NETX90 RE ECS V5.2.0-32.xml

Hilscher NETX90 RE ECS V5.2.0-64.xml

Hilscher NETX90 RE ECS V5.2.0-96.xml

Hilscher NETX90 RE ECS V5.2.0-128.xml

The **PLC** must import the **XML** file corresponding to the input and output area sizes selected on the instrument.

For example, if **INP.REG. = 128** and **OUT.REG. = 128** are set on the instrument, the **PLC** must import the file:

**Hilscher NIC 50-RE ECS V2.2 128 Byte.xml**

It is possible to import multiple files with different sizes. However, in this case, the automatic search and configuration function for network devices will not be available.

# INPUT/OUTPUT PARAMETERS

## FUNCTION IN 1

### INPUT 1 FUNCTION

Selection of the function associated with Input 1. [1401]

**Selectable values:**

VALUE	DESCRIPTION
<b>Zero</b>	Performs zero calibration. [0]
<b>Tare</b>	Executes auto-tare. [1]
<b>Del.Tar</b>	Clears the tare. [2]
<b>Peak</b>	Resets the peak function. [3]
<b>Hold</b>	Freezes the acquired weight. [4]
<b>Send</b>	Transmits data on demand or prints based on Protocol 1 programming. [5]
<b>Log</b>	Activates the data logger function. [6]
<b>Default</b>	Zero

## FUNCTION IN 2

### INPUT 2 FUNCTION

Selection of the function associated with Input 2. [1402]

**Selectable values:**

VALUE	DESCRIPTION
<b>Zero</b>	Performs zero calibration [0].
<b>Tare</b>	Executes auto-tare [1].
<b>Del.Tar</b>	Clears the tare [2].
<b>Peak</b>	Resets the peak function [3].
<b>Hold</b>	Freezes the acquired weight [4].
<b>Send</b>	Transmits data on demand or prints based on Protocol 1 programming [5].
<b>Log</b>	Activates the data logger function [6].
<b>Default</b>	Zero.

## SET OUT 1

### SET POINT 1 FUNCTION CONFIGURATION

## SET OUT 2

### SET POINT 2 FUNCTION CONFIGURATION

## SET OUT 3

### SET POINT 3 FUNCTION CONFIGURATION

## SET OUT 4

### SET POINT 4 FUNCTION CONFIGURATION

## SET OUTX SUBMENU

## WEIGHT

### ASSOCIATED WEIGHT

Select in sequence 5 threshold operation criteria: [1403] [1410] [1417] [1424]

Comparison with net weight, gross weight, or peak. If peak is selected, the comparison is performed with the last recorded peak value, even if the peak function is not active. Unbalance is activated if the corresponding parameter is programmed. It represents the difference between the value measured by the load cell and the average value.

#### Selectable values:

VALUE	DESCRIPTION
NET	The relay output is active in Net Weight mode [0].
GROSS	The relay output is active in Gross Weight mode [1].
PEAK	The relay output is active in Peak Mode [2].
PROCESS	The relay output is active when the instrument operates normally [3].
UNBALANCED	The relay output is active when the load is unbalanced [4].
Default	GROSS.

## LOGIC

Selection of the output state as normally open or closed: [1404] [1411] [1418] [1425]

VALUE	DESCRIPTION
n. oPEn.	The relay is normally open [0].
n.CloSE	The relay is normally closed [1].
Default	n. oPEn.

## POLARITY

Select whether positive or negative values should be compared: [1405] [1412] [1419] [1426]

VALUE	DESCRIPTION
PoSIt..	The output is active with positive weight [0].
nEGAt.	The output is active with negative weight [1].
ALL	The output is active with both positive and negative weight [2].
Default	PoSIt..

## STABILITY

Select whether only stable weight values or also unstable values should be compared: [1406] [1413] [1420] [1427]

VALUE	DESCRIPTION
norMAL	The output is active with unstable weight [0].
StABLE	The output is active with stable weight [1].
Default	norMAL.

## HYSTERESIS

### THRESHOLD 1 HYSTERESIS [1407] [1414] [1421] [1428]

Hysteresis value relative to the set threshold value.

**Value range:** 0 to Full Scale

**Default:** 2

## DURATION

### THRESHOLD 1 TIMING [1408] [1415] [1422] [14296]

Time value, in tenths of a second, during which the output associated with threshold 1 remains enabled after the weight value exceeds the set threshold.

Once this time elapses, even if the weight value is still above the set point, the output is automatically disabled.

If the time is set to zero, the function is disabled.

**Value range:** 0.00 to 9.99 seconds

**Default:** 0

## DELAY

### THRESHOLD 1 DELAY [1409] [1416] [1423] [1430]

Time value, in tenths of a second, after which the output associated with threshold 1 is enabled once the weight value exceeds the set threshold.

If the time is set to zero, the function is disabled.

**Value range:** 0.00 to 9.99 seconds

**Default:** 0

Once this time elapses, even if the weight value is still above the set point, the output is automatically disabled.

# WEIGHING PARAMETERS

## OPERATING MODE

### INSTRUMENT OPERATION

Selection of the instrument's operating mode. If switching from **FREE** mode to **METRIC** mode, authentication via an authorized personnel password is required to confirm the setting.

VALUE	DESCRIPTION
<b>FREE</b>	Free operation mode. [0]
<b>METRIC</b>	Metric instrument operation mode. [1]
<b>Default</b>	FREE

## STABILITY

### STABILITY [1303]

This parameter defines the number of divisions required to consider the weight stable.

A higher number of divisions allows the transmitter to detect weight stability more quickly, which is necessary when performing tare and print commands.

VALUE	DESCRIPTION
<b>0</b>	Weight always considered stable.
<b>1</b>	Stability determined quickly.
<b>2</b>	Stability determined with average parameters.
<b>3</b>	Stability determined accurately.
<b>4</b>	Stability determined with maximum accuracy.
<b>Default</b>	2

## AUTOZERO

### AUTOZERO AT POWER-ON [1304-1305]

This parameter defines the maximum weight that can be zeroed at startup.

This operation corresponds to a system zero calibration and is performed only if the weight is stable and below the set value.

**Value range:** 0 to Full Scale

**Default:** 0

## ZERO TRACKING

### ZERO TRACKING [1306]

This function allows for a temporary zero calibration, compensating for possible thermal drift in weight measurements.

When the transmitter is turned off, the previous zero calibration is automatically restored.

The maximum weight that can be zeroed using this parameter is 2% of the system's full scale.

To disable this function, set the value to 0.

VALUE	DESCRIPTION
NONE	Zero tracking disabled.
1	0.5 div/sec.
2	1 div/sec.
3	2 div/sec.
4	3 div/sec.
Default	NONE

## ZERO BAND

### ZERO BAND [1307]

This parameter defines the number of divisions that can be zeroed by pressing the front panel Zero button or using the associated input.

**Value range:** 0 to 200.

**Default:** 100

## LOAD CELL CAPACITY

### LOAD CELL CAPACITY PERCENTAGE [1307]

This parameter modifies the percentage of the load cell's capacity, calculated as the total capacity divided by the number of installed load cells.

For example, if 4 load cells are used with a total capacity of 8000 kg, the full-scale (F.S.) capacity per single load cell is 2000 kg.

If the value is set to 50, the overload warning for a single load cell will trigger when the weight exceeds 1000 kg.

**Value range:** 0 to 200.

**Default:** 100

## FILTER PARAMETERS

### SET FILTER

#### WEIGHT FILTER VALUE [1201]

This parameter regulates not only the display update speed but also the update rate of the serial and analog output. The maximum display update speed is limited to 25 Hz.

- Higher filter values speed up the weight update.
- Lower filter values slow down the weight update.

Factor (Hz)	Settling Time (ms)	ADC Frequency (Hz)	Readings (N)	Monotony Time (ms)	Oscillation Time (ms)	Oscillation Range (div)
<b>MANUAL [0]</b>		Adjustable	Adjustable	Adjustable	Adjustable	Adjustable
<b>25 [1]</b>	40	250	11	200	4000	16
<b>10 [2]</b>	100	250	23	200	3000	16
<b>5 [3]</b>	200	250	47	200	2500	16
<b>2 [4]</b>	500	100	49	200	2000	16
<b>1.25 [5]</b>	800	100	79	250	1500	25
<b>1 [6]</b>	1000	100	99	300	1500	25
<b>0.8 [7]</b>	1250	50	59	400	1500	25
<b>0.5 [8]</b>	2000	50	99	500	1200	30
<b>0.25 [9]</b>	4000	25	99	600	1000	30

*Default: 1.25 Hz*

**The following parameters are visible and configurable only if the filter selection is set to MANUAL.**

### FREQUENCY

#### ADC SPEED [1202]

This parameter adjusts the weight acquisition frequency. If changing this parameter to values higher than 5 Hz, the weight must be stable. If instability is detected, the instrument will immediately display an error message.

**Selectable values:**

- 5 [0]
- 10 [1]
- 25 [2]
- 50 [3]
- 100 [4]
- 250 [5]

## **AVERAGE**

### **NUMBER OF READINGS FOR AVERAGE [1203]**

*This parameter sets the number of readings the filter will use to determine the average weight value.*

**Value range:** 0 to 99

## **MONOTONY TIME**

### **MONOTONY TIME [1204]**

*This parameter is used to stabilize the weight when continuous variations of the last digit are detected. It is normally used when weight resolution is higher than 10,000 divisions or when the input signal sensitivity is low.*

**Value range:** 0 to 999 ms

## **OSCILLATION TIME**

### **OSCILLATION TIME [1205]**

*This parameter is used in conjunction with Oscillation Range to dampen slow and repetitive weight variations, typical in lifting systems. Enter the oscillation time value in milliseconds (ms).*

**Value range:** 0 to 9999 ms

## **OSCILLATION RANGE**

### **OSCILLATION RANGE [1206]**

*Like the Oscillation Time parameter, this is used to dampen oscillations. Enter the oscillation value in weight divisions.*

**Value range:** 0 to 99

# FUNCTIONAL CHARACTERISTICS SETTINGS

## STANDBY TIME

### STANDBY [1001]

Inactivity time after which the instrument automatically enters low brightness mode and keyboard lock state.

**0** = Function disabled.

**Value Range:** 0 to 999

**Default:** 0

## KEY LOCK

### KEYBOARD LOCK [1002]

Configuration of 4 binary values corresponding to the 4 keys.

- 0 → Key not locked
- 1 → Key locked

**Example:** 0101 locks the 2nd and 4th keys.

**Value Range:** 0000 to 1111

**Default:** 0000

## ACCESS CODE

### PASSWORD SETTING [1003]

If set, a password must be entered to access the programming menu.

After the first access, the password will not be required again until standby mode is activated or the instrument is powered off.

**Value Range:** 0000 to 9999

**Default:** 0000 (No Password)

## LANGUAGE

### LANGUAGE SETTING

Allows the selection of the operator interface language.

**Selectable values:** ITALIAN, ENGLISH, GERMAN

**Default:** ITALIAN

## **PEAK FUNCTION**

### **PEAK FUNCTION [1004]**

Enables or disables the peak function, allowing it to be referenced to either net weight or gross weight. If the application does not require this function, it can be disabled.

**Selectable Values:**

- NONE [0]
- NET [1]
- GROSS [2]

**Default:** NONE

## **UNBALANCE ALARM**

### **UNBALANCE ALARM**

*If programmed, this defines the maximum weight difference between the value measured by a single load cell and the average value.*

**0** = Function disabled.

**Value Range:** 0 to Full Scale

**Default:** 0

# DATE AND TIME ADJUSTMENT

The display of this menu is only available if the hardware includes a real-time clock.

## DATE

### DATE ADJUSTMENT

Parameter for setting the current date.

**Selectable format:** *dd.mm.yy*

- **dd:** *from 01 to 31*
- **mm:** *from 01 to 12*
- **yy:** *from 00 to 99*

**Default:** *Current date*

## TIME

### TIME ADJUSTMENT

Parameter for setting the current time.

**Selectable format:** *hh:mm*

**hh:** *from 00 to 23*

**mm:** *from 00 to 59*

**Default:** *Current time*

## OPERATING FUNCTIONS - LOAD CELL SIMULATION

In the event of a load cell failure, the instrument can be set to simulate the faulty cell by interpolating the values from the adjacent load cells.

This procedure allows the operator to continue using the instrument even when a load cell is broken, while waiting for its replacement.

## OPERATING FUNCTIONS - SINGLE CELL DISPLAY

The instrument can display the mV/V signals of all load cells or the relative percentages and total weight, allowing for easy identification of structural imbalances and potential issues.

Net	1:	0.985
	2:	1.352
	3:	0.458
	4:	0.625
		<b>2.962 kg</b>

1:	25.0	
2:	24.3	
3:	26.7	
4:	24.0	
		<b>100.0 %</b>

1:	0.2351	
2:	0.4320	
3:	0.3747	
4:	0.2987	
		<b>0.3351 mV</b>

1:	0.2351	5:	0.3574	
2:	0.4320	6:	0.5519	
3:	0.3747	7:	0.2331	
4:	0.2987	8:	0.2548	
				<b>0.3422 mV</b>

## LOAD CELL EMULATION

As described in the previous section, when a load cell is damaged or disconnected, the following message appears on the display, and the relay **output 2** contact opens:

**OL x**

(Where x represents the number of the faulty load cell)

- Pressing the **PRG** button excludes the faulty cell from the weighing system, allowing the system to continue functioning.
- The instrument automatically assigns a weight value to the excluded cell based on the average of the weights detected by the other operational load cells.
- If the **"OTHER DISPLAYS"** function is activated, during the individual weight values display, the automatically assigned value for the excluded cell will flash on the display.
- In the individual signal display mode, the **mV/V** value of the excluded cell will not be shown.

When the faulty cell is repaired or replaced, the instrument will automatically detect and reintegrate it into the weighing system without requiring any further operator intervention.

## SETUP MEMORY UPLOAD / DOWNLOAD

This function allows the upload or download of the instrument's **setup memory**.

- **Download function:** Saves the instrument's setup parameters into a file.
- **Upload function:** Configures the instrument using setup parameters read from a file.

To use these functions, the corresponding procedure ("Receive File" or "Transmit File") must be activated on the TESTER 1008 and the instrument must be connected via RS232.

Once inside the **IN/OUT** test function, the following message will appear:

(Next step depends on the specific message shown on the instrument's screen.)

## TEST FUNCTIONS – IN/OUT TEST

### DISPLAY FORMAT

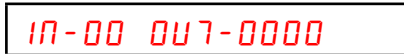





### Where:

- “IN” and “OUT” indicate the status of inputs 1 and 2 (0 = inactive, 1 = active).
- The output status for outputs 1 and 2 is shown (0 = inactive, 1 = active).
- If available, optional outputs 3 and 4 are also displayed.

### Switching Output States

To toggle the state of an output, press the corresponding output button:

OUT1	OUT2	OUT3	OUT4
			

To exit the test mode, press and hold the designated button.



## TEST FUNCTIONS – RS232 AND RS485 TEST

This test verifies the communication on the RS232 and RS485 serial lines by:

- **Echoing** the received string back to the sender.
- **Displaying** the number of received strings.
- **Displaying** the number of characters received in the last string.

This allows for real-time monitoring and validation of serial communication functionality.

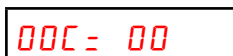

## TEST FUNCTIONS – ANALOG OUTPUT TEST

Once inside the Analog Output Test function, the following message will appear on the display:



00C = 00

### Where:

"0%" indicates the output value (current or voltage, depending on the selected setting), expressed as a percentage of the full scale.

### Adjusting the Output Value:

The output value can be changed from **0%** to **100%** in **10%** increments by pressing the designated



and



buttons:

# SERIAL COMMUNICATION PROTOCOLS

The continuous transmission is performed at the weight update frequency, depending on the serial baud rate.

For **ETHERNET** communication, the continuous transmission frequency is limited to **12.5 Hz**.

## ASCII PROTOCOL: CONTINUOUS, AUTOMATIC, AND ON-DEMAND

### Total Weight Transmission:

If the serial port is configured to transmit only the total weight (parameter **DATA** in the **CONNECTIONS** menu set to **TOTAL WEIGHT**), the transmission format is:

STX	<Total weight status>	<Total weight>	ETX	<chksum>	EOT
-----	-----------------------	----------------	-----	----------	-----

### Single Weight Transmission:

If the serial port is configured to transmit individual weight values (parameter **DATA** in the **CONNECTIONS** menu set to **SINGLE WEIGHTS**), the string length varies depending on the number of active channels:

STX	<Weight status>	<Weight 1>	<Weight 2>	...	<Weight 8>	ETX	<chksum>	EOT
-----	-----------------	------------	------------	-----	------------	-----	----------	-----

Where:

PARAMETER	DESCRIPTION
<b>STX</b>	Start of text (0x02h)
<b>ETX</b>	End of text (0x03h)
<b>EOT</b>	End of transmission (0x04h)
<b>&lt;status&gt;</b>	Encoded character representing weight status (see table below).
<b>&lt;weight&gt;</b>	8-character ASCII field, right-justified, without leading zeros. Includes decimal point and negative sign if applicable.
<b>&lt;checksum&gt;</b>	Checksum calculated using XOR of all characters from STX to ETX (excluding STX and ETX).
<b>&lt;weighing ID&gt;</b>	7-character ASCII field, right-justified, without leading zeros.
<b>Default</b>	Zero.

## WEIGHT STATUS ENCODING TABLE

Each bit in the status byte represents a specific condition (1 = TRUE):

Bit 7	Bit 6	Bit 5	Bit 4	Bit 3	Bit 2	Bit 1	Bit 0
0	0	1	1	Tare Entered	Zero band	Stable weight	Zero center

## WEIGHT FIELD VALUES

CONDITION	DISPLAYED VALUE
Overweight	"^ ^ ^ ^ ^ ^ ^ ^ ^ ^"
Underweight (> 9999999)	" _ _ _ _ _ _ _ _ _ _"
Weight Reading Error	" O-L "

The transmitted weight value can be **Net Weight**, **Gross Weight**, or **Peak Value**, based on the **MODE** parameter selection in the serial communication port configuration menu.

## CHECKSUM CALCULATION

The checksum (<chksum>) is computed as follows:

1. Perform **XOR** operation on all characters from **STX** to **ETX** (excluding STX and ETX).
2. Split the result into two nibbles (4-bit values).
3. Convert each nibble into an ASCII-encoded character.

### Example Calculation:

**XOR result:** 5Dh

**Checksum:** "5Dh" → ASCII values: 35h and 44h

## WEIGHT VARIATION CONDITION FOR AUTOMATIC & MANUAL PROTOCOLS

In automatic and manual communication protocols, the weight must change by at least 20 divisions between two consecutive transmissions.

## SLAVE PROTOCOL

### LIST OF AVAILABLE COMMANDS:

1. Request net weight, gross weight, and peak value.
2. Auto-tare command.
3. Semi-automatic zero command.
4. Peak value reset command.
5. Program two weight thresholds.
6. Request programmed thresholds.
7. Activate logical outputs.
8. Request the status of logical inputs.
9. Store thresholds in permanent memory.
10. Switch display from gross weight to net weight.
11. Switch display from net weight to gross weight.
12. Tare cancellation command.
13. Request net weight.
14. Request gross weight.

### MASTER-SLAVE COMMUNICATION

The unit connected to the instrument (typically a personal computer) functions as the MASTER and is the only unit that can initiate a communication process.

- **The communication process always consists of:**
  1. The **MASTER** transmitting a request string.
  2. The **SLAVE** responding accordingly.

This ensures a structured and controlled exchange of data between the master and the instrument.

### COMMAND FORMAT DESCRIPTION:

- **Double quotes** (" ") enclose constant characters (case-sensitive).
- **Angle brackets** (< >) enclose variable numerical fields.
- **The field <Addr>** represents the instrument identifier.

### COMMUNICATION ADDRESSING:

1. RS485 Communication:
  - The address is calculated by adding **80h** to the instrument's address.
  - Example: If the instrument address is **3**, then:  
**<Addr> = 80h + 03h = 83h**

## 2. RS232 Communication:

- The <Addr> field must always be **81h**.

## 3. Ethernet Communication:

- The <Addr> field must always be **FFh**.

This addressing system ensures proper identification of the instrument across different communication protocols.

NO.	COMMAND DESCRIPTION	MASTER REQUEST	WT68 RESPONSE
1	Request Net Weight, Gross Weight, or Peak Value	<Addr> "N" EOT	<Addr> "N" <status> <weight> ETX <checksum> EOT or <Addr> NAK EOT
2	Auto-Tare Command	<Addr> "A" EOT	<Addr> "A" ACK EOT or <Addr> NAK EOT
3	Semi-Automatic Zero Command	<Addr> "Z" EOT	<Addr> "Z" ACK EOT or <Addr> NAK EOT
4	Reset Peak Value Command	<Addr> "X" EOT	<Addr> "X" ACK EOT or <Addr> NAK EOT
5	Programming Two Weight Thresholds	<Addr> "S" <s1> <s2> ETX <checksum> EOT	<Addr> "S" ACK EOT or <Addr> NAK EOT
6	Request Programmed Thresholds	<Addr> "R" EOT	<Addr> "R" <s1> <s2> ETX <checksum> EOT or <Addr> NAK EOT
7	Activate Logical Outputs	<Addr> "U" <outputs> EOT	<Addr> "U" ACK EOT or <Addr> NAK EOT
8	Request Logical Input Status	<Addr> "I" EOT	<Addr> "I" <inputs> ETX <checksum> EOT or <Addr> NAK EOT
9	Store Thresholds in Permanent Memory	<Addr> "E" EOT	<Addr> "E" ACK EOT or <Addr> NAK EOT
10	Switch Display from Gross Weight to Net Weight	<Addr> "CN" EOT	<Addr> "C" ACK EOT or <Addr> NAK EOT
11	Switch Display from Net Weight to Gross Weight	<Addr> "CL" EOT	<Addr> "C" ACK EOT or <Addr> NAK EOT
12	Tare Cancellation Command	<Addr> "DT" EOT	<Addr> "D" ACK EOT or <Addr> NAK EOT
13	Request Net Weight (used for PDAT06 repeater program)	<Addr> "W" "N" EOT	<Addr> "W" <status rep> <net weight> ETX <checksum> EOT or <Addr> NAK EOT
14	Request Gross Weight (used for PDAT06 repeater program)	<Addr> "W" "G" EOT	<Addr> "W" <status rep> <gross weight> ETX <checksum> EOT or <Addr> NAK EOT

## ERROR HANDLING

If a communication error occurs or the WT68 does not recognize a command, it will respond with:

<Addr> NAK EOT

## DATA FORMATTING NOTES

- <s1> and <s2>: Formatted as weight fields.
- <outputs> and <inputs>: Represented as a single **ASCII** character encoded as per the table below (bit = 1 if the input/output is active).

BIT 7	BIT 6	BIT 5	BIT 4	BIT 3	BIT 2	BIT 1	BIT 0
0	0	1	1	0	0	Input 2 / Output 2	Input 1 / Output 1

## FIELD DESCRIPTIONS AND ENCODING TABLES

### 1. Status Field (<Status Field>)

This field is a single encoded character where **bit = 1** when the condition is true.

Bit 7	Bit 6	Bit 5	Bit 4	Bit 3	Bit 2	Bit 1	Bit 0
0	0	1	1	0 = Net Weight / 1 = Gross Weight	Zero Band	Stable Weight	Center Zero

### 2. Weight Fields (<Net> <Gross>)

The net weight and gross weight fields are 8-character ASCII values, right-justified, without leading zeros. They include a decimal point and a negative sign if applicable.

#### Special Conditions:

- **Overload Condition:** "^^^^^^^^"
- **Underweight Condition (Negative weight greater than -999999):** "\_\_\_\_\_"
- **Weight Reading Error:** "O-L"

### 3. Threshold Fields (<s1> <s2> <s3> <s4>)

Formatted like the net/gross weight fields.

- **Thresholds <s3> and <s4>** must only be managed if the hardware has 4 outputs.
- **Threshold values** must be lower than the full-scale parameter.

### 4. Logical Input Status (<Inputs>)

Encoded as a single character, where **bit = 1** when the condition is true.

Bit 7	Bit 6	Bit 5	Bit 4	Bit 3	Bit 2	Bit 1	Bit 0
0	0	1	1	Output 4	Output 3	Output 2	Output 1

### 5. Logical Output Status (<uscite>)

Encoded as a single character, where bit = 1 when the condition is true.

Bit 7	Bit 6	Bit 5	Bit 4	Bit 3	Bit 2	Bit 1	Bit 0
0	0	1	1	Output 4	Output 3	Output 2	Output 1

### PRINTER PROTOCOL

The data transmission protocol is designed for Plus printers.

• **Printing can be initiated by:**

1. Pressing a button (see **OPERATING FUNCTIONS** section).
2. Using an input signal (see **I/O SETTINGS** section).

Below is an example of a printout format:

(Provide a sample printout if available, or specify the expected structure of the printed data.)

```

21/06/30      16:34
Net           209.0 kg
Gross        211.5 kg
Tare         2.5 kg
Peak         268.5 kg
Code         212456
21/06/18      16:38
    
```

```

Cella 1      17.1 %
Cella 2      10.5 %
Cella 3      11.8 %
Cella 4       8.5 %
Cella 5      21.9 %
Cella 6      11.9 %
Cella 7       9.6 %
Cella 8       8.7 %

Lordo        270.0 kg
    
```

### PRINTING CONDITIONS

- The date is printed only if the hardware includes a real-time clock.
- The peak value is printed only if the peak calculation function is enabled.

### CONDITIONS REQUIRED FOR PRINTING:

1. **Stable Weight** (or weight stabilizes within 3 seconds after the command).
2. **Weight Change:** Since the last recorded weight, the value must have changed by at least 20 divisions (weight delta).
3. **Gross Weight Limit:** The gross weight must be below the maximum capacity.

These conditions ensure that the printed data is valid, stable, and meaningful.

## MODBUS RTU PROTOCOL

The addresses provided in the tables follow the standard addressing format specified in the Modicon **PI-MBUS-300** reference guide. Below is an excerpt from the guide to help users communicate with the instrument:

“All data addresses in Modbus messages are referenced to zero. The first occurrence of a data item is addressed as item number zero.

### **For example:**

- **Coil 1** in a programmable controller is addressed as coil 0000 in the Modbus message data address field.
- **Coil 127** (decimal) is addressed as coil 007E (hex) (126 decimal).
- **Holding Register 40001** is addressed as register 0000 in the data address field of the message. The function code field already specifies a ‘holding register’ operation. Therefore, the ‘4XXXX’ reference is implicit.”

### **Data Entry and Backup:**

- To confirm the insertion of a new value into **EEPROM**, perform the **MAKE – BACKUP** function.
- If this function is not executed, turning off the WT68 will restore the previous value before modification.

### **Addressing and Numerical Format**

- Unless otherwise specified, numeric values (such as addresses, codes, and data) are expressed in decimal format.
- The **MODBUS RTU** protocol is only available on COM2 (RS485).

This ensures consistent communication and data integrity when interfacing with the WT68 using MODBUS RTU.

## COMMUNICATION ERROR HANDLING

- Communication strings are verified using **CRC** (Cyclical Redundancy Check) to ensure data integrity.
- In the event of a communication error, the slave does not send any response.
- The master must implement a timeout for receiving a response.
- If the timeout expires without receiving a response, the master must assume that a communication error has occurred.

This error-handling mechanism ensures reliable communication between the master and slave devices in the system.

## HANDLING ERRORS IN RECEIVED DATA

If a communication string is received correctly but cannot be executed, the slave responds with an **EXCEPTION RESPONSE** as described in the table below:

CODE	DESCRIPTION
1	ILLEGAL FUNCTION (The function is invalid or not supported)
2	ILLEGAL DATA ADDRESS (The specified data address is unavailable)
3	ILLEGAL DATA VALUE (The received data has an invalid value)

## SUPPORTED FUNCTIONS

FUNCTION CODE	DESCRIPTION
01	READ COIL STATUS (Read the status of logical outputs)
02	READ INPUT STATUS (Read the status of logical inputs)
03	READ HOLDING REGISTERS (Read programmable registers)
04	READ INPUT REGISTERS (Read "read-only" registers)
05	FORCE SINGLE COIL (Write status of a single output)
06	PRESET SINGLE REGISTER (Write a programmable register)
15	FORCE MULTIPLE COILS (Write multiple outputs)
16	PRESET MULTIPLE REGISTERS (Write multiple registers)
<b>Funct + 80h</b>	EXCEPTION RESPONSE

If a function is not supported, the system returns an **EXCEPTION RESPONSE**, which corresponds to the **Function Code + 80h**.

*This structure ensures that communication errors are properly handled and that only valid operations are executed by the slave device.*

## LIST OF HOLDING REGISTERS - MODBUS PROTOCOL

The parameters of the instrument that can be read or programmed through the available communication interfaces, depending on the hardware configuration, are listed in the following table.

Registers of type **R** are read-only, while those of type **W** are writable.

For **Modbus TCP** protocol, the instrument address (Unit Identifier field) must always be FFh.

If a fieldbus other than Modbus is used, the input area will contain only **R** (Read-only) or **R/W** (Read/Write) registers, while the output area will contain only **W** (Write-only) or **R/W** (Read/Write) registers.

All registers have a size of **16** bits.

(Insert the list of Modbus holding registers here, including address, description, type (R/W), and unit if applicable.)

Address	Holding Register	R/W	Notes
0001	Status Register	R	See related table.
0002	Gross Weight (MSW)	R	INT value - Most significant word
0003	Gross Weight (LSW)	R	INT value - Least significant word
0004	Net Weight (MSW)	R	INT value - Most significant word
0005	Net Weight (LSW)	R	INT value - Least significant word
0006	Peak (MSW)	R	INT value - Most significant word
0007	Peak (LSW)	R	INT value - Least significant word
0008	Digital Inputs	R	See related table.
0009	Digital Outputs	R	See related table.
0010	Balancing Status	R	See related table.
0051	Weight 1 (MSW)	R	INT value - Most significant word
0052	Weight 1 (LSW)	R	INT value - Least significant word
...	...	...	...
0065	Weight 8 (MSW)	R	INT value - Most significant word
0066	Weight 8 (LSW)	R	INT value - Least significant word
0101	Weighing Net Weight (MSW)	R	INT value - Most significant word
0102	Weighing Net Weight (LSW)	R	INT value - Least significant word
0103	Weighing Code (MSW)	R	INT value - Most significant word
0104	Weighing Code (LSW)	R	INT value - Least significant word
0201	Set-Point 1 (MSW)	R/W	INT value - Most significant word
0202	Set-Point 1 (LSW)	R/W	INT value - Least significant word
0203	Set-Point 2 (MSW)	R/W	INT value - Most significant word
0204	Set-Point 2 (LSW)	R/W	INT value - Least significant word
0205	Set-Point 3 (Optional, MSW)	R/W	INT value - Most significant word
0206	Set-Point 3 (Optional, LSW)	R/W	INT value - Least significant word
0207	Set-Point 4 (Optional, MSW)	R/W	INT value - Most significant word
0208	Set-Point 4 (Optional, LSW)	R/W	INT value - Least significant word
0501	Data Register (MSW)	W	INT value - Most significant word (See related table)
0502	Data Register (LSW)	W	INT value - Least significant word (See related table)
0503	Command Register	W	See related table.
1001	Standby Function	R/W	INT value.

1002	Keyboard Lock Function	R/W	See related table.
1003	Password Function	R/W	INT value.
1004	Peak Function	R/W	See correspondence in the Functions menu.
1005	Data Logger Function	R/W	See correspondence in the Functions menu.
1006	Data Logger Trigger	R/W	See correspondence in the Functions menu.
1007	Data Logger Frequency	R/W	See correspondence in the Functions menu.
1008	Language	R/W	See correspondence in the Functions menu.
1009	Unbalance Threshold (MSW)	R/W	INT value - Most significant word.
1010	Unbalance Threshold (LSW)	R/W	INT value - Least significant word.
1101	Weight Division Value	R/W	See related table.
1102	Decimals	R/W	
1103	Load Cell Capacity (MSW)	R/W	INT value - Most significant word.
1104	Load Cell Capacity (LSW)	R/W	INT value - Least significant word.
1105	Load Cell 1 Sensitivity	R/W	INT value.
1106	Load Cell 2 Sensitivity	R/W	INT value.
1107	Load Cell 3 Sensitivity	R/W	INT value.
1108	Load Cell 4 Sensitivity	R/W	INT value.
1109	Load Cell 5 Sensitivity	R/W	INT value.
1110	Load Cell 6 Sensitivity	R/W	INT value.
1111	Load Cell 7 Sensitivity	R/W	INT value.
1112	Load Cell 8 Sensitivity	R/W	INT value.
1113	Fixed Tare (MSW)	R/W	INT value - Most significant word.
1114	Fixed Tare (LSW)	R/W	INT value - Least significant word.
1115	Calibration Gravity (MSW)	R/W	INT value - Most significant word.
1116	Calibration Gravity (LSW)	R/W	INT value - Least significant word.
1117	Operating Zone Gravity (MSW)	R/W	INT value - Most significant word.
1118	Operating Zone Gravity (LSW)	R/W	INT value - Least significant word.
1119	Measurement Unit	R/W	INT value.
1120	Number of Used Load Cells	R/W	INT value.
1151	Calibration Table Zero Signal (MSW)	R/W	INT value - Most significant word.
1152	Calibration Table Zero Signal (LSW)	R/W	INT value - Least significant word.
1153	Calibration Table Signal P1 (MSW)	R/W	INT value - Most significant word.
1154	Calibration Table Signal P1 (LSW)	R/W	INT value - Least significant word.
1155	Calibration Table Signal P2 (MSW)	R/W	INT value - Most significant word.
1156	Calibration Table Signal P2 (LSW)	R/W	INT value - Least significant word.
1157	Calibration Table Signal P3 (MSW)	R/W	INT value - Most significant word.
1158	Calibration Table Signal P3 (LSW)	R/W	INT value - Least significant word.
1159	Calibration Table Signal P4 (MSW)	R/W	INT value - Most significant word.
1160	Calibration Table Signal P4 (LSW)	R/W	INT value - Least significant word.
1161	Calibration Table Signal P5 (MSW)	R/W	INT value - Most significant word.
1162	Calibration Table Signal P5 (LSW)	R/W	INT value - Least significant word.
1163	Calibration Table Value P1 (MSW)	R/W	INT value - Most significant word.

<b>1164</b>	Calibration Table Value P1 (LSW)	R/W	INT value - Least significant word.
<b>1165</b>	Calibration Table Value P2 (MSW)	R/W	INT value - Most significant word.
<b>1166</b>	Calibration Table Value P2 (LSW)	R/W	INT value - Least significant word.
<b>1167</b>	Calibration Table Value P3 (MSW)	R/W	INT value - Most significant word.
<b>1168</b>	Calibration Table Value P3 (LSW)	R/W	INT value - Least significant word.
<b>1169</b>	Calibration Table Value P4 (MSW)	R/W	INT value - Most significant word.
<b>1170</b>	Calibration Table Value P4 (LSW)	R/W	INT value - Least significant word.
<b>1171</b>	Calibration Table Value P5 (MSW)	R/W	INT value - Most significant word.
<b>1172</b>	Calibration Table Value P5 (LSW)	R/W	INT value - Least significant word.
<b>1201</b>	Filter Factor	R/W	See related table.
<b>1202</b>	ADC Output Rate	R/W	See related table.
<b>1203</b>	Number of Readings for Average	R/W	INT value.
<b>1204</b>	Monotony Time	R/W	INT value.
<b>1205</b>	Oscillation Time	R/W	INT value.
<b>1206</b>	Oscillation Range	R/W	INT value.
<b>1251</b>	Load Cell 1 Balancing Factor	R/W	INT value.
<b>1252</b>	Load Cell 2 Balancing Factor	R/W	INT value.
<b>1253</b>	Load Cell 3 Balancing Factor	R/W	INT value.
<b>1254</b>	Load Cell 4 Balancing Factor	R/W	INT value.
<b>1255</b>	Load Cell 5 Balancing Factor	R/W	INT value.
<b>1256</b>	Load Cell 6 Balancing Factor	R/W	INT value.
<b>1257</b>	Load Cell 7 Balancing Factor	R/W	INT value.
<b>1258</b>	Load Cell 8 Balancing Factor	R/W	INT value.
<b>1301</b>	Full Scale (MSW)	R/W	INT value - Most significant word.
<b>1302</b>	Full Scale (LSW)	R/W	INT value - Least significant word.
<b>1303</b>	Weight Stability	R/W	See related table.
<b>1304</b>	Autozero at Power-On (MSW)	R/W	INT value - Most significant word.
<b>1305</b>	Autozero at Power-On (LSW)	R/W	INT value - Least significant word.
<b>1306</b>	Zero Tracking	R/W	See related table.
<b>1307</b>	Zeroable Divisions (MSW)	R/W	INT value - Most significant word.
<b>1308</b>	Zeroable Divisions (LSW)	R/W	INT value - Least significant word.
<b>1309</b>	Load Cell Capacity Percentage	R/W	INT value.
<b>1401</b>	Input 1 Function	R/W	See related table.
<b>1402</b>	Input 2 Function	R/W	See related table.
<b>1403</b>	Output 1 Mode - Function	R/W	See related table.
<b>1404</b>	Output 1 Mode - Logic	R/W	See related table.
<b>1405</b>	Output 1 Mode - Polarity	R/W	See related table.
<b>1406</b>	Output 1 Mode - Stability	R/W	See related table.
<b>1407</b>	Output 1 Hysteresis	R/W	INT value.
<b>1408</b>	Output 1 Timing	R/W	INT value.
<b>1409</b>	Output 1 Delay	R/W	INT value.
<b>1410</b>	Output 2 Mode - Function	R/W	See related table.
<b>1411</b>	Output 2 Mode - Logic	R/W	See related table.

<b>1412</b>	Output 2 Mode - Polarity	R/W	See related table.
<b>1413</b>	Output 2 Mode - Stability	R/W	See related table.
<b>1414</b>	Output 2 Hysteresis	R/W	INT value.
<b>1415</b>	Output 2 Timing	R/W	INT value.
<b>1416</b>	Output 2 Delay	R/W	INT value.
<b>1417</b>	Output 3 Mode - Function	R/W	See related table.
<b>1418</b>	Output 3 Mode - Logic	R/W	See related table.
<b>1419</b>	Output 3 Mode - Polarity	R/W	See related table.
<b>1420</b>	Output 3 Mode - Stability	R/W	See related table.
<b>1421</b>	Output 3 Hysteresis	R/W	INT value.
<b>1422</b>	Output 3 Timing	R/W	INT value.
<b>1423</b>	Output 3 Delay	R/W	INT value.
<b>1424</b>	Output 4 Mode - Function	R/W	See related table.
<b>1425</b>	Output 4 Mode - Logic	R/W	See related table.
<b>1426</b>	Output 4 Mode - Polarity	R/W	See related table.
<b>1427</b>	Output 4 Mode - Stability	R/W	See related table.
<b>1428</b>	Output 4 Hysteresis	R/W	INT value.
<b>1428</b>	Output 4 Timing	R/W	INT value.
<b>1430</b>	Output 4 Delay	R/W	INT value.
<b>1501</b>	Analog Tare (MSW)	R/W	INT value - Most significant word.
<b>1502</b>	Analog Tare (LSW)	R/W	INT value - Least significant word.
<b>1503</b>	Analog Full Scale (MSW)	R/W	INT value - Most significant word.
<b>1504</b>	Analog Full Scale (LSW)	R/W	INT value - Least significant word.
<b>1505</b>	Analog Output Mode	R/W	See related table.
<b>1506</b>	Analog Output Range	R/W	See related table.
<b>1507</b>	Analog Zero Adjustment	R/W	INT value. Zero point adjustment for analog output. To complete the adjustment procedure, the save data command must be sent to the Command Register.
<b>1508</b>	Analog Full Scale Adjustment	R/W	INT value. Full-scale point adjustment for analog output. To complete the adjustment procedure, the save data command must be sent to the Command Register.
<b>2000</b>	Monitor Register	W	The programmed value is automatically copied into Monitor Register (2100).
<b>2100</b>	Monitor Register	R	—

**TABLE A - STATUS REGISTER CODING**

BIT	15	14	13	12	11	10	9	8
Description	Weight Delta	Output 4	Output 3	Output 2	Output 1	Input 2	Input 1	Execute Backup
BIT	7	6	5	4	3	2	1	0
Description	Not Calibrated	Weight Error	Overload	Underload	Tare Applied	Zero Band	Stable Weight	Zero Center

**TABLE B - KEYBOARD LOCK CODING**

BIT	15÷4	3	2	1	0
Description	Not Used	SET Key	FUN Key	0 Key	PRG Key

**WARNING:** Bits 15 to 4 are not managed and are always set to 0.

**TABLE C - INPUT/OUTPUT CODING**

BIT	15÷2	3	2	1	0
Description	Not Used	OUT 4 Active	OUT 3 Active	IN/OUT 2 Active	IN/OUT 1 Active

**WARNING:** Bits 15 to 4 are not managed and are always set to 0.

**TABLE D - VALUE CODING FOR DIVISION AND DECIMALS**

ADDRESS	DESCRIPTION	ACCEPTED VALUES
1101	Division Value	1 - 2 - 5 - 10 - 20 - 50
1102	Number of Decimals	0 - 1 - 2 - 3 - 4

**TABLE E - BALANCING STATUS CODING**

VALUE	DESCRIPTION
0	Initial state, reference weight correctly acquired
1	Load Cell 1 Balancing Successfully Completed
...	Load Cell n Balancing Successfully Completed
8	Load Cell 8 Balancing Successfully Completed

**TABLE F - COMMAND REGISTER / DATA REGISTER CODING**

REGISTER VALUE	COMMAND REGISTER FUNCTION	DATA REGISTER FUNCTION
0x0001	Semi-Automatic Zero	—
0x0002	Auto-Tare	—
0x0003	Peak Reset	—
0x0004	Zero Calibration (**)	—
0x0005	Full-Scale Calibration (**)	Reference weight value in MSB and LSB
0x0006	Analog Test	Value between 0 and 100 in 10-step intervals (in LSB)
0x0007	Save Data to Permanent Memory	—
0x000A	Weighing Execution Command	—
0x000B	Switch from Gross Weight to Net Weight	—
0x000C	Switch from Net Weight to Gross Weight	—
0x000D	Acquire Zero Signal (Table Calibration)	—
0x000E	Set Reference Weight for Balancing	Reference weight value in MSB and LSB
0x000F	Load Cell Balancing (Repeat n times based on the number of cells)	Cell number (from 1 to N)
0x3FFF	Enable Output Data Area (*)	—

**NOTES:****(\*) Output Data Area Management in Fieldbus:**

- Instrument parameters managed in the Fieldbus Output Data Area will not be modified until this command is sent.
- When the instrument powers on, the Output Data Area is completely reset.
- The Fieldbus Master must read the Input Data Area values, copy them into the respective Output Data Area registers, and then send the enable command to the Command Register.
- Failure to send this command results in all parameters in the Output Data Area being reset upon startup.
- Do not use this function if using the CANopen fieldbus.

**(\*) Configuration Mode:\*\***

- The instrument is in configuration mode when the **TRUE** flag is set during **SETUP** menu access or when connected to the PC software "VTW Connect".

**() Calibration Conditions:\*\***

- Zero Calibration and Full-Scale Calibration are only available if the instrument is operating in **FREE** mode or in **METRIC** mode with the calibration jumper enabled.

<b>UD_CAPAC</b>	<p><b>WEIGHING SYSTEM CAPACITY</b></p> <p>Set the value corresponding to the sum of the nominal capacities of the load cells. This value represents the full-scale capacity of the weighing system.</p> <p>When the maximum capacity value is modified, the system automatically performs a theoretical weight calibration.</p> <p>Refer to the register in the <b>Object Dictionary (OD)</b> named <b>UD_CAPAC</b>.</p>																																								
<b>UD_SENS</b>	<p><b>LOAD CELL SENSITIVITY</b></p> <p>Set the value corresponding to the average sensitivity of the load cells at nominal capacity, expressed in mV/V.</p> <p><b>Accepted range:</b> 0.5 to 4 mV/V.</p> <p>If no value is programmed, the system defaults to 2 mV/V.</p> <p>When the sensitivity value is modified, the system automatically performs a theoretical weight calibration.</p> <p>Refer to the register in the <b>Object Dictionary (OD)</b> named <b>UD_SENS</b>.</p>																																								
<b>UD_DIV</b>	<p><b>DIVISION VALUE</b></p> <p>The division value represents the smallest measurable weight increment and is expressed in units of measurement, selectable between <b>0.0001</b> and <b>50</b>.</p> <p>This value must be set according to the required precision of the weighing system. Refer to the UD_DIV register in the Object Dictionary (OD) for configuration.</p> <table border="1" data-bbox="470 1003 1474 1272"> <thead> <tr> <th>REGISTER VALUE</th> <th>0</th> <th>1</th> <th>2</th> <th>3</th> <th>4</th> <th>5</th> <th>6</th> <th>7</th> <th>8</th> </tr> </thead> <tbody> <tr> <td>DIVISION VALUE</td> <td>0.0001</td> <td>0.0002</td> <td>0.0005</td> <td>0.001</td> <td>0.002</td> <td>0.005</td> <td>0.01</td> <td>0.02</td> <td>0.05</td> </tr> <tr> <th>REGISTER VALUE</th> <th>9</th> <th>10</th> <th>11</th> <th>12</th> <th>13</th> <th>14</th> <th>15</th> <th>16</th> <th>17</th> </tr> <tr> <td>DIVISION VALUE</td> <td>0.1</td> <td>0.2</td> <td>0.5</td> <td>1</td> <td>2</td> <td>5</td> <td>10</td> <td>20</td> <td>50</td> </tr> </tbody> </table>	REGISTER VALUE	0	1	2	3	4	5	6	7	8	DIVISION VALUE	0.0001	0.0002	0.0005	0.001	0.002	0.005	0.01	0.02	0.05	REGISTER VALUE	9	10	11	12	13	14	15	16	17	DIVISION VALUE	0.1	0.2	0.5	1	2	5	10	20	50
REGISTER VALUE	0	1	2	3	4	5	6	7	8																																
DIVISION VALUE	0.0001	0.0002	0.0005	0.001	0.002	0.005	0.01	0.02	0.05																																
REGISTER VALUE	9	10	11	12	13	14	15	16	17																																
DIVISION VALUE	0.1	0.2	0.5	1	2	5	10	20	50																																
<b>AI_DEC_DGT_PV</b>	<p><b>DECIMAL DIGITS</b></p> <p>This parameter defines the number of decimal places displayed. When the weighing system's capacity is modified, the system automatically selects the most suitable division value and decimal places to achieve the best precision within <b>10,000 divisions</b>. The value transmitted from the <b>AI_INPUT_PV</b> register will be an integer where the last digits represent the desired decimals. The user must divide the received value accordingly to obtain the correct weight. Refer to the AI_DEC_DGT_PV register in the Object Dictionary (OD) for configuration.</p>																																								
<b>UD_ZERO_CAL</b>	<p><b>ZERO CALIBRATION</b></p> <p>This operation should be performed with an empty scale to reset the displayed weight. The procedure can be repeated multiple times.</p> <p>Zero calibration is executed by writing the hexadecimal string <b>6F72657Ah</b> ('o','r','e','z') into the appropriate sub-register of <b>UD_ZERO_CAL</b>. Refer to the UD_ZERO_CAL register in the Object Dictionary (OD) for configuration.</p>																																								

<b>UD_W_CAL</b>	<p><b>SAMPLE WEIGHT CALIBRATION</b></p> <p>Before performing this operation, a reference weight must be placed on the scale. If the entered value exceeds the instrument's resolution, the calibration will not be performed. Calibration is always repeatable and is executed by writing 6E617073h ('n', 'a', 'p', 's') into the <b>UD_W_CAL</b> register, and the reference weight value into the <b>UD_SPAN_VAL</b> register.</p> <p>This value must be multiplied by a power of 10 based on the configured decimal places (e.g., if 3 decimals are set and a <b>2 kg</b> weight is used, the stored value should be <b>2 × 10<sup>3</sup> = 2000</b>).</p> <p>Refer to the UD_W_CAL register in the Object Dictionary (OD) for configuration.</p>
<b>UD_ZERO_S</b>	<p><b>SEMI-AUTOMATIC ZERO</b></p> <p>This function is used to correct minor zero shifts in the scale.</p> <p>Refer to the <b>UD_ZERO_S</b> register in the Object Dictionary (OD) for configuration.</p>

**WARNING:** The operational functions described so far take immediate effect once the corresponding register is accessed. However, to permanently store the new register values, it is necessary to save the data.

Refer to the **STORE\_PAR** register within the Object Dictionary (OD) to ensure that all changes are properly saved and retained after a system restart.

## **FILTER**

<b>AI_FILT_CON</b>	<p><b>WEIGHT FILTER</b></p> <p>This parameter controls the digital filtering action applied to the measured weight.</p> <p>The filter value ranges from <b>0</b> to <b>9</b>, where <b>0</b> applies minimal filtering and <b>9</b> applies maximum filtering. Increasing the value enhances the digital filter's effect.</p> <p>Refer to the <b>FILT</b> register within the Object Dictionary (OD) for configuration.</p>
--------------------	---

## **NUMBER OF LOAD CELLS**

<b>UD_N_CELLS</b>	<p><b>NUMBER OF LOAD CELLS IN THE SYSTEM</b></p> <p>This parameter defines the number of load cells connected to the weighing system. Refer to the UD_N_CELLS register within the Object Dictionary (OD) for configuration.</p>
-------------------	---

## OUTPUT RATE OF THE CONVERTER

AI_ADC_RATE	<b>OUTPUT RATE OF THE CONVERTER</b>	
	This parameter indicates the output rate of the converter.	
	<b>Valore registro</b>	<b>Hz</b>
	0	5
	1	10
	2	25
	3	50
	4	100
	5	250
<p><b>Refer to the AI_ADC_RATE register within the Object Dictionary (OD).</b></p> <p>The value in the register will only take effect if the filter (AI_FILT_CON) is set to 0.</p>		

**WARNING:** The operational functions described so far take immediate effect once the corresponding register is accessed. However, to permanently store the new register values, it is necessary to save the data.

Refer to the STORE\_PAR register within the Object Dictionary (OD) to ensure that all changes are properly saved and retained after a system restart.

## EXAMPLES

### ZERO CALIBRATION

With the scale empty and stable, write the hexadecimal value **0004** into the Command Register (0503).

To permanently save the new Zero value in memory, write the hexadecimal value **0007** into the Command Register.

### FULL-SCALE CALIBRATION

1. Place the reference weight on the scale (e.g., **1256 kg**).
2. Write the hexadecimal equivalent of the reference weight (**04E8**) into the Data Register (**0501** and **0502**).
3. Write the hexadecimal value **0005** into the Command Register (**0503**).
4. It is possible to write to both the Command Register and Data Register simultaneously using the multiple register write function.
5. To permanently save the new Full-Scale value in memory, write the hexadecimal value **0007** into the Command Register.

## USING SERIAL APPLICATIONS VIA USB PORT

The “VTW Connect” PC software allows:

- Complete configuration of all setup parameters.
- Hardware testing for different sections.
- Access to the instrument’s documentation.
- Firmware updates for the instrument.
- Long-term storage of acquired weight values via the **Data Logger function**.
- **Saving and loading** the instrument’s configuration parameters to/from a file.

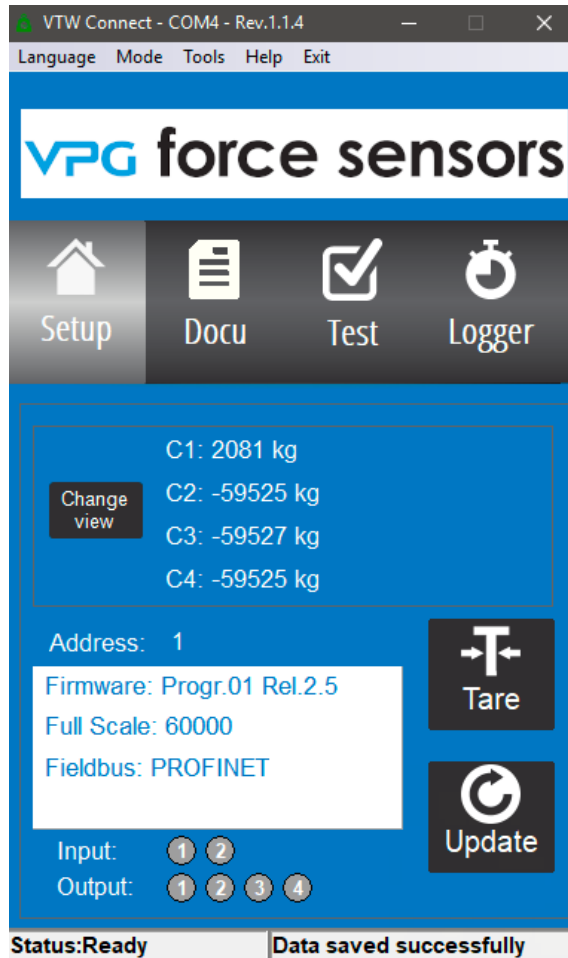

# FIELDBUS PROTOCOL

The following table lists the input area registers (produced by the instrument and read by the master), which are common to all fieldbus protocols: **PROFIBUS, PROFINET, ETHERCAT, and ETHERNET/IP**.

- The registers have a **16-bit** size.
- The input area is updated at a fixed frequency of **125 Hz** (80 Hz for PROFIBUS).
- The input area size configured in the fieldbus master must match the size configured in the instrument.

## INPUT DATA AREA

Byte	Register Address	INPUT AREA REGISTER	Notes
1-2	0	Status Register	See related table.
3-4	1	Gross Weight (MSW)	INT value - Most significant word.
5-6	2	Gross Weight (LSW)	INT value - Least significant word.
7-8	3	Net Weight (MSW)	INT value - Most significant word.
9-10	4	Net Weight (LSW)	INT value - Least significant word.
11-12	5	Peak (MSW)	INT value - Most significant word.
13-14	6	Peak (LSW)	INT value - Least significant word.
15-16	7	Load Cell 1 Weight (MSW)	INT value - Most significant word.
17-18	8	Load Cell 1 Weight (LSW)	INT value - Least significant word.
19-20	9	Load Cell 2 Weight (MSW)	INT value - Most significant word.
21-22	10	Load Cell 2 Weight (LSW)	INT value - Least significant word.
23-24	11	Load Cell 3 Weight (MSW)	INT value - Most significant word.
25-26	12	Load Cell 3 Weight (LSW)	INT value - Least significant word.
27-28	13	Load Cell 4 Weight (MSW)	INT value - Most significant word.
29-30	14	Load Cell 4 Weight (LSW)	INT value - Least significant word.
31-32	15	Load Cell 5 Weight (MSW)	INT value - Most significant word.
33-34	16	Load Cell 5 Weight (LSW)	INT value - Least significant word.
35-36	17	Load Cell 6 Weight (MSW)	INT value - Most significant word.
37-38	18	Load Cell 6 Weight (LSW)	INT value - Least significant word.
39-40	19	Load Cell 7 Weight (MSW)	INT value - Most significant word.
41-42	20	Load Cell 7 Weight (LSW)	INT value - Least significant word.
43-44	21	Load Cell 8 Weight (MSW)	INT value - Most significant word.
45-46	22	Load Cell 8 Weight (LSW)	INT value - Least significant word.
47-48	23	Digital Inputs	See related table.
49-50	24	Digital Outputs	See related table.
51-52	25	Monitor Register	Value corresponds to the equivalent register in the output area.
53-54	26	Net Weighing Weight (MSW)	INT value - Most significant word.
55-56	27	Net Weighing Weight (LSW)	INT value - Least significant word.
57-58	28	Weighing Code (MSW)	INT value - Most significant word.
59-60	29	Weighing Code (LSW)	INT value - Least significant word.
61-62	30	Set-Point 1 (MSW)	INT value - Most significant word.
63-64	31	Set-Point 1 (LSW)	INT value - Least significant word.

<b>65-66</b>	32	Set-Point 2 (MSW)	INT value - Most significant word.
<b>67-68</b>	33	Set-Point 2 (LSW)	INT value - Least significant word.
<b>69-70</b>	34	Set-Point 3 (Optional, MSB)	INT value - Most significant word.
<b>71-72</b>	35	Set-Point 3 (Optional, LSB)	INT value - Least significant word.
<b>73-74</b>	36	Set-Point 4 (Optional, MSB)	INT value - Most significant word.
<b>75-76</b>	37	Set-Point 4 (Optional, LSB)	INT value - Least significant word.
<b>77-78</b>	38	Load Cell Capacity (MSW)	INT value - Most significant word.
<b>79-80</b>	39	Load Cell Capacity (LSW)	INT value - Least significant word.
<b>81-82</b>	40	Load Cell 1 Sensitivity	INT value.
<b>83-84</b>	41	Load Cell 2 Sensitivity	INT value.
<b>85-86</b>	42	Load Cell 3 Sensitivity	INT value.
<b>87-88</b>	43	Load Cell 4 Sensitivity	INT value.
<b>89-90</b>	44	Load Cell 5 Sensitivity	INT value.
<b>91-92</b>	45	Load Cell 6 Sensitivity	INT value.
<b>93-94</b>	46	Load Cell 7 Sensitivity	INT value.
<b>95-96</b>	47	Load Cell 8 Sensitivity	INT value.
<b>97-98</b>	48	Weight Division Value	See related table.
<b>99-100</b>	49	Decimal Places	See related table.
<b>101-102</b>	50	Fixed Tare (MSW)	INT value - Most significant word.
<b>103-104</b>	51	Fixed Tare (LSW)	INT value - Least significant word.
<b>105-106</b>	52	Stand-By Function	INT value.
<b>107-108</b>	53	Keyboard Lock Function	See related table.
<b>109-110</b>	54	Password Function	INT value.
<b>111-112</b>	55	Peak Function	See corresponding entry in the Functions menu.
<b>113-114</b>	56	Data-Logger Function	See corresponding entry in the Functions menu.
<b>115-116</b>	57	Data-Logger Trigger	See corresponding entry in the Functions menu.
<b>117-118</b>	58	Data-Logger Frequency	See corresponding entry in the Functions menu.
<b>119-120</b>	59	Language	See corresponding entry in the Functions menu.
<b>121-122</b>	60	Filter Factor	See corresponding entry in the Filter menu.

## READING EXAMPLE

To read the gross weight from the WT68, you need to read addresses 3 to 6 in the Input Area.

To read the net weight, you need to read bytes **7** to **10** in the Input Area.

For example, if the instrument displays a gross weight of 12351, the corresponding bytes will contain:

	Byte 3	Byte 4	Byte 5	Byte 6
Hex	00	00	30	3F

The following table lists the Output Area Registers (written by the master and acquired by the instrument), which are common to all fieldbus protocols: **PROFIBUS**, **PROFINET**, **ETHERCAT**, and **ETHERNET/IP**.

- The registers have a 16-bit size.
- The output area registers written by the master are read by the instrument at a fixed frequency of 125 Hz (80 Hz for PROFIBUS).
- The Output Data Area size configured in the fieldbus master must match the size configured in the instrument.

## OUTPUT DATA AREA

Byte	Register Address	OUTPUT AREA REGISTER	Notes
1-2	0	Command Register	See related table.
3-4	1	Data Register (MSW)	INT value - Most significant word (See Table).
5-6	2	Data Register (LSW)	INT value - Least significant word (See Table).
7-8	3	Monitor Register	Value corresponds to the equivalent register in the output area.
9-10	4	Set-Point 1 (MSW)	INT value - Most significant word.
11-12	5	Set-Point 1 (LSW)	INT value - Least significant word.
13-14	6	Set-Point 2 (MSW)	INT value - Most significant word.
15-16	7	Set-Point 2 (LSW)	INT value - Least significant word.
17-18	8	Set-Point 3 (Optional, MSB)	INT value - Most significant word.
19-20	9	Set-Point 3 (Optional, LSB)	INT value - Least significant word.
21-22	10	Set-Point 4 (Optional, MSB)	INT value - Most significant word.
23-24	11	Set-Point 4 (Optional, LSB)	INT value - Least significant word.
25-26	12	Load Cell Capacity (MSW)	INT value - Most significant word.
27-28	13	Load Cell Capacity (LSW)	INT value - Least significant word.
29-30	14	Load Cell 1 Sensitivity	INT value.
31-32	15	Load Cell 2 Sensitivity	INT value.
33-34	16	Load Cell 3 Sensitivity	INT value.
35-36	17	Load Cell 4 Sensitivity	INT value.
37-38	18	Load Cell 5 Sensitivity	INT value.
39-40	19	Load Cell 6 Sensitivity	INT value.
40-41	20	Load Cell 7 Sensitivity	INT value.
43-44	21	Load Cell 8 Sensitivity	INT value.
45-46	22	Weight Division Value	See related table.
47-48	23	Decimal Places	See related table.
49-50	24	Fixed Tare (MSW)	INT value - Most significant word.
51-52	25	Fixed Tare (LSW)	INT value - Least significant word.
53-54	26	Stand-By Function	INT value.
55-56	27	Keyboard Lock Function	See related table.
57-58	28	Password Function	INT value.
59-60	29	Peak Function	See corresponding entry in the Functions menu.
61-62	30	Data-Logger Function	See corresponding entry in the Functions menu.
63-64	31	Data-Logger Trigger	See corresponding entry in the Functions menu.
65-66	32	Data-Logger Frequency	See corresponding entry in the Functions menu.
67-68	33	Language	See corresponding entry in the Functions menu.
69-70	34	Filter Factor	See corresponding entry in the Filter menu.
71-72	35	Output Rate ADC	See corresponding entry in the Filter menu.
73-74	36	Number of Readings for Average	INT value.
75-76	37	Monotony Time	INT value.
77-78	38	Oscillation Time	INT value.
79-80	39	Oscillation Range	INT value.

81-82	40	Full Scale (MSW)	INT value - Most significant word.
83-84	41	Full Scale (LSW)	INT value - Least significant word.
85-86	42	Weight Stability	See corresponding entry in the Functions menu.
87-88	43	Autozero on Startup (MSW)	INT value - Most significant word.
89-90	44	Autozero on Startup (LSW)	INT value - Least significant word.
91-92	45	Zero Tracking	See corresponding entry in the Functions menu.
93-94	46	Zeroable Divisions ( >0< button)	INT value.
95-96	47	Input Function 1	See corresponding entry in the Functions menu.
97-98	48	Input Function 2	See corresponding entry in the Functions menu.
99-100	49	Output 1 Mode – Function	See corresponding entry in the Functions menu.
101-102	50	Output 1 Mode – Logic	See corresponding entry in the Functions menu.
103-104	51	Output 1 Mode – Polarity	See corresponding entry in the Functions menu.
105-106	52	Output 1 Mode – Stability	See corresponding entry in the Functions menu.
107-108	53	Output 1 Hysteresis	INT value.
109-110	54	Output 1 Timing	INT value.
111-112	55	Output 1 Delay	INT value.
113-114	56	Output 2 Mode – Function	See corresponding entry in the Functions menu.
115-116	57	Output 2 Mode – Logic	See corresponding entry in the Functions menu.
117-118	58	Output 2 Mode – Polarity	See corresponding entry in the Functions menu.
119-120	59	Output 2 Mode – Stability	See corresponding entry in the Functions menu.
121-122	60	Output 2 Hysteresis	INT value.
123-124	61	Output 2 Timing	INT value.
125-126	62	Output 2 Delay	INT value.

## WRITING EXAMPLES

To write setup parameters, follow the example below:

1. In bytes 1-2 (Command Register), write the **HEX** value **3FFF**, which unlocks the internal write area of the WT68.

### Example: Changing Setup Values:

The WT68 is initially programmed with factory values. The following parameters are to be modified:

**Load Cell Capacity** → 15000

**Load Cell Sensitivity** → 2.9965 mV/V

**Weight Division Value** → 2

Capacity	Byte 17	Byte 18	Byte 19	Byte 20
Hex	00	00	3A	98

Sensitivity	Byte 21	Byte 22
Hex	75	0D

Division	Byte 23	Byte 24
Hex	00	0A

2. Save the new values by writing the **HEX** value **7** into bytes **1-2** (Command Register).

**Note:**

- The WT68 does not accept writing a value identical to the existing one.
- **To perform Zero and Full Scale Calibration**, it is not necessary to unlock the internal write area of the WT68.

**Zero and Full Scale Calibration**

Zero Calibration:

- Ensure the weighing system is empty.
- Write **HEX** value **4** in the Command Register.
- The new Zero value is acquired.

**Full Scale Calibration:**

- Place a known weight on the system.
- Write the corresponding value into the Data Register (bytes **3** to **6**).
- Write **HEX** value **5** into the Command Register.
- The new weight value will be saved and automatically displayed.

## TROUBLESHOOTING GUIDE

PROBLEM	POSSIBLE CAUSE	SOLUTION
<b>The display shows the message O-L</b>	The acquired weight is not detectable because the load cell is missing or incorrectly connected.	Check the load cell connections.
<b>The display shows a dash (-) on the upper display</b>	The acquired weight is not representable because it exceeds the available digits or is greater than the load cell capacity.	Adjust the setup parameters to be compatible with the system specifications.
<b>The number of decimal places is incorrect.</b>	The correct division value has not been selected.	Select the correct division value in the main menu.
<b>The instrument does not turn on.</b>	The power supply voltage is incorrect.	Power the instrument with the correct voltage.
<b>The weight display is stuck.</b>	The load cell is malfunctioning or incorrectly connected.	Use a multimeter to measure 5V DC between EXC+ and EXC- and a lower voltage between SENSE+ and SENSE- (the longer the distance between the instrument and load cells, the lower the SENSE voltage). Also, check for millivolt variations between SGN+ and SGN- when loading or unloading the cell.
<b>Inputs and/or outputs are not working correctly.</b>	Wiring errors or incorrect software settings.	Use the I/O Test Function to check the proper functioning of inputs and outputs, and verify the settings in the specific program.
<b>Serial communication is not working properly.</b>	The installation was not performed correctly. The serial interface mode selection is incorrect.	Check the connections as described in the installation manual. Select the correct interface settings.
<b>The semi-automatic zero function does not work.</b>	The gross weight exceeds the semi-automatic zero limit. The weight is not stabilizing.	To restore zero, calibrate the weight. Wait for weight stabilization or adjust the weight filter parameter.
<b>The semi-automatic tare function does not work.</b>	The gross weight is negative or exceeds the maximum capacity. The weight is not stabilizing.	Verify the gross weight. Wait for weight stabilization or adjust the weight filter parameter.

# Certificate of Compliance

## Certificate Number:

E546509

## Report Reference:

E546509-20250306

## Issue Date:

2025-06-06

Issued to:

**VPG Technology Development Ltd.**  
**Tsela Ha-Har 18, Modi'In Makabim-Re'Ut Israel 7179574**  
**Israel**

This certificate confirms that representative samples of:

AUDIO/VIDEO, INFORMATION AND COMMUNICATION TECHNOLOGY  
EQUIPMENT - COMPONENT

Complementary Recognition Under  
AUDIO/VIDEO, INFORMATION AND COMMUNICATION TECHNOLOGY  
EQUIPMENT CERTIFIED FOR CANADA - COMPONENT

**See Addendum Page for Product Designation(s).**

Have been evaluated by UL in accordance with the component requirements in the Standard(s) indicated on this Certificate. UL Recognized components are incomplete in certain constructional features or restricted in performance capabilities and are intended for installation in complete equipment submitted for investigation to UL LLC.

**UL 62368-1 and CSA C22.2 No. 62368-1:19, Audio/Video, Information and Communication Technology Equipment - Part 1: Safety Requirements**

Additional Information:

See the UL Online Certifications Directory at <https://iq.ulprospector.com> for additional information.

This Certificate of Compliance indicates that representative samples of the product described in the certification report have met the requirements for UL certification. It does not provide authorization to apply the UL Recognized Component Mark. Only the Authorization Page that references the Follow-Up Services Procedure for ongoing surveillance provides authorization to apply the UL Mark.

Only those products bearing the UL Recognized Component Mark should be considered as being UL Certified and covered under UL's Follow-Up Services.

Look for the UL Recognized Component Mark on the product.



David Piecuch  
UL Mark Certification Program Owner



© 2025 UL LLC. All rights reserved.  
Form-ULID-019496 – ver 1.0

Any information and documentation involving UL Mark services are provided on behalf of UL LLC (UL) or any authorized licensee of UL. For questions, please contact UL Solutions Customer Service at <https://www.ul.com/contact-us>.

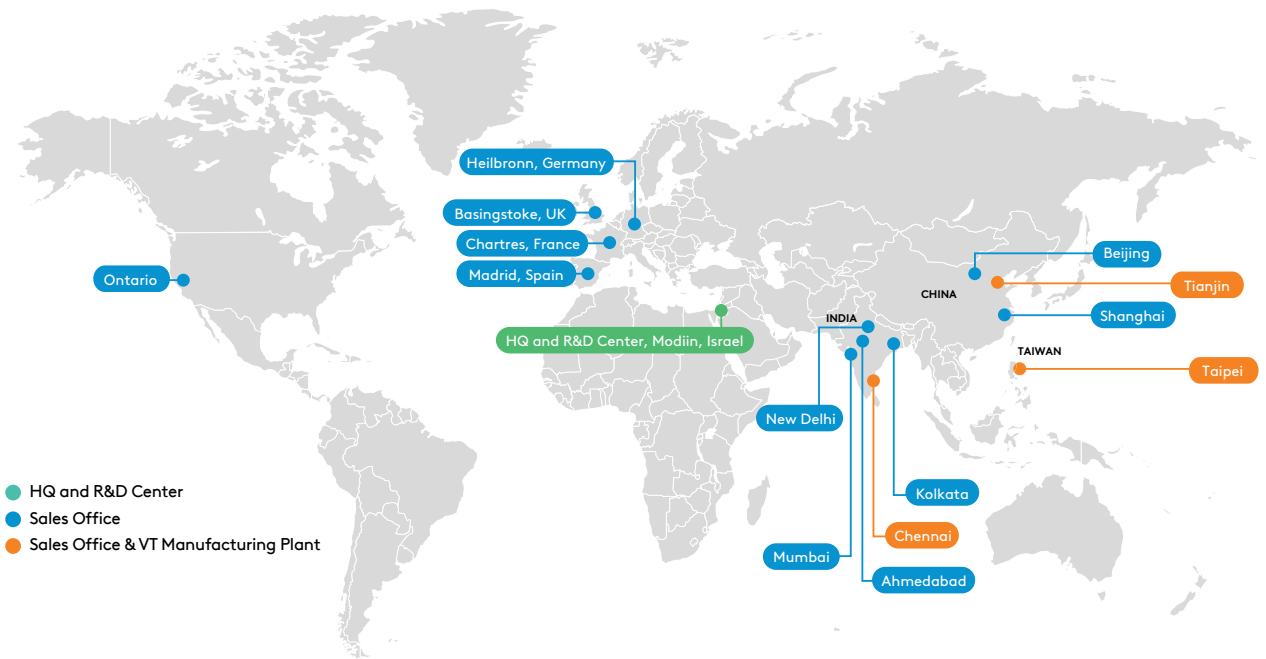

## Sales Contact

[vpgfs.americas@vpgsensors.com](mailto:vpgfs.americas@vpgsensors.com)

[vpgfs.asia@vpgsensors.com](mailto:vpgfs.asia@vpgsensors.com)

[vpgfs.emea@vpgsensors.com](mailto:vpgfs.emea@vpgsensors.com)

### OEM Customization Services:

[vpgfs.customsolutions@vpgsensors.com](mailto:vpgfs.customsolutions@vpgsensors.com)

### Strain Gage Installation Services:

[vpgfs.bonding@vpgsensors.com](mailto:vpgfs.bonding@vpgsensors.com)

**VPG force sensors**

Celtron • Revere • Sensortronics • TedeA-Huntleigh



[VPGforcesensors.com](http://VPGforcesensors.com)

© Copyright 2025 Vishay Precision Group. © Registered trademarks of Vishay Precision Group. All rights reserved. Printed in Czech Republic. Specifications subject to change without notice.