

WT 14

WEIGHT INDICATOR/TRANSMITTER WITH
SERIAL, ANALOG, AND FIELDBUS OUTPUT.

Technical manual

Software version WT1401_38



VPG force sensors

Celtron • Revere • Sensortronics • Tedeá-Huntleigh

INDEX

PRECAUTIONS	6
• WARNING.....	6
INTRODUCTION	7
• AVAILABLE VERSIONS	7
TECHNICAL SPECIFICATIONS	8
INSTALLATION	9
• GENERAL	9
• OVERALL DIMENSIONS	10
• ELECTRICAL INSTALLATION	10
• INSTRUMENT POWER SUPPLY	11
• LOAD CELL CONNECTIONS.....	11
• WIRING DIAGRAM FOR J-BOX JBG4-C WITH WT 14.....	12
• LOGIC INPUTS.....	12
• LOGIC OUTPUTS	13
• SERIAL COMMUNICATION	13
• ANALOG OUTPUT (OPTIONAL).....	14
• USB DEVICE (SPECIFICATION 2.0 COMPLIANT; FULL-SPEED 12 MBPS)	15
• OPTIONAL FIELDBUS CONNECTIONS	15
• ETHERNET CONNECTION.....	15
• CONNECTION TO MASTER	16
• ETHERNET/IP CONNECTION.....	16
• PROFINET CONNECTION	17
• ETHERCAT CONNECTION.....	17
• MAC ADDRESS IN DEVICES WITH INDUSTRIAL ETHERNET FIELDBUS	18
• PROFIBUS CONNECTION	19
• CANOPEN CONNECTION	20

FRONT PANEL OF THE INSTRUMENT	21
• DISPLAY	21
• STAND-BY FUNCTION	21
• LED INDICATORS	21
• MULTIRANGE FUNCTION	21
USING THE KEYBOARD	22
• KEYBOARD LOCK/UNLOCK FUNCTIONS	24
• EXITING THE CONFIGURATION MENU	24
INFO DISPLAY	25
• ERROR MESSAGES	25
• FIXED MESSAGES	25
• FLASHING MESSAGE, ALTERNATING WITH THE DETECTED WEIGHT	25
OPERATING FUNCTIONS	26
• GROSS WEIGHT / NET WEIGHT DISPLAY	26
• ZEROING AND AUTO-TARE	27
• ZEROING FUNCTION	27
• AUTO-TARE FUNCTION	28
• PEAK FUNCTION	28
• WEIGHT FREEZE FUNCTION	28
• TEST FUNCTIONS – RS232 AND RS485	28
• TEST FUNCTIONS – ANALOG OUTPUT TEST	29
• TEST FUNCTIONS – INPUT/OUTPUT	29
• WEIGHT THRESHOLD PROGRAMMING	29
• WEIGHT ACQUISITION	30
• CALIBRATION JUMPER	30
CONFIGURATION	31
• GENERAL INFORMATION	31
• PROCEDURE FOR MODIFYING AND ENTERING PARAMETERS	32

• INFO MENU	33
• TEST MENU	34
• SETUP MENU	34
SETUP MENU DIAGRAM	35
CONFIGURATION PARAMETERS	36
CALIBRATION MENU	36
• CONFIGURATION/CALIBRATION EXAMPLE	39
CALIBRATION WITH SAMPLE WEIGHTS	40
• ZERO CALIBRATION	40
• FULL-SCALE CALIBRATION	40
• LINEARIZATION PROCEDURE	41
TABLE CALIBRATION	42
• EXIT FROM CALIBRATION MENU	43
ANALOG OUTPUT PARAMETERS (OPTIONAL)	44
SERIAL OUTPUT PARAMETERS	46
• COM 2 PARAMETERS WHEN PRESENT RS485	48
• COM 2 PARAMETERS WHEN PROFINET / ETHERCAT IS PRESENT	50
• PARAMETERS COM 2 WHEN ETHERNET IP IS PRESENT	51
• COM 2 PARAMETERS WHEN ETHERNET IS PRESENT	53
• COM 2 PARAMETERS WHEN PROFIBUS DP IS PRESENT	54
• COM 2 PARAMETERS WHEN CANOPEN IS PRESENT	55
• COM2 PARAMETERS APPLY WHEN ETHERCAT IS PRESENT	56
INPUT/OUTPUT PARAMETERS	58
WEIGHING PARAMETERS	62
FILTER - SETTING FILTER PARAMETERS	64
SETTING FUNCTIONAL FEATURES	66
DATE AND TIME ADJUSTMENT	69
• DATE ADJUSTMENT	69

• TIME ADJUSTMENT	69
UPLOAD / DOWNLOAD FUNCTION	69
ACCESS VIEWING	70
• ACCESS VIEWING PROCEDURE	70
FISCAL MEMORY CONSULTATION	71
SERIAL COMMUNICATION PROTOCOLS	72
• CONTINUOUS, AUTOMATIC, AND MANUAL ASCII PROTOCOL	72
• WEIGHT AND CHECKSUM FIELD DESCRIPTIONS	72
• SPECIAL CASES FOR <WEIGHT> FIELD	73
• SLAVE PROTOCOL	73
• CONTROL FORMAT DESCRIPTION	74
• ADDRESSING BASED ON COMMUNICATION INTERFACE	74
• COMMAND LIST & FORMATS	75
• WEIGHT DATA FORMATTING	77
• SPECIAL CONDITIONS & ERROR STATES	77
• PRINTER PROTOCOL	78
• MODBUS RTU PROTOCOL	79
• COMMUNICATION ERROR HANDLING	79
• RECEIVED DATA ERROR HANDLING	79
• SUPPORTED FUNCTIONS	80
• LIST OF HOLDING REGISTERS – MODBUS PROTOCOL	80
• LIST OF HOLDING REGISTERS – MODBUS PROTOCOL	81
• TABLE A - REGISTER STATUS CODING	83
• TABLE B - KEYPAD LOCK CODING	83
• TABLE C - INPUT/OUTPUT ENCODING	84
• TABLE D - DIVISION VALUE AND DECIMAL VALUE ENCODING	84
• TABLE E - COMMAND REGISTER / DATA REGISTER ENCODING	84
• EXAMPLES	85

- INSTRUMENT RESPONSE TIMES 86
- VTW CONNECT - THE USE OF SERIAL APPLICATIONS VIA THE USB PORT 87**
- FIELD BUS PROTOCOL 88
- INPUT DATA AREA 88
- READING EXAMPLE 90
- OUTPUT DATA AREA 91
- WRITING EXAMPLES 93
- CANOPEN - DESCRIPTION 94
- SPECIFICATIONS 95
- CANOPEN - OBJECT DICTIONARY - COMMUNICATION PROFILE AREA 96
- GENERIC PARAMETERS 96
- SDO SERVER PARAMETERS 96
- T_PDO COMMUNICATION PARAMETERS 97
- T_PDO MAPPING PARAMETERS 97
- T_PDO COMMUNICATION PARAMETERS 98
- T_PDO MAPPING PARAMETERS 98
- MANUFACTURER-DEFINED PARAMETERS 99
- TROUBLESHOOTING 102**

PRECAUTIONS

READ this manual **BEFORE** using or maintaining the instrument.

FOLLOW these instructions carefully.

KEEP this manual for future reference.



WARNING

The purpose of this manual is to provide the operator with fundamental guidelines for the installation and proper use of the instrument, using explanatory texts and figures.

Installation, maintenance, and repairs must only be carried out by specialized personnel who have read and understood this manual. "Specialized personnel" refers to individuals who, due to their training and professional experience, have been expressly authorized by the Safety Manager of the plant to perform the installation.

Power the instrument using a voltage within the limits specified in its technical characteristics.

It is the user's responsibility to ensure that the installation complies with current regulations.

Any attempt to disassemble or modify the instrument without express authorization will void the warranty and release VPG from any liability.

Installation and maintenance of this instrument should only be performed by qualified personnel.

Exercise caution when performing checks, tests, and adjustments while the instrument is powered on.

Make electrical connections only when the power supply is turned off.

Failure to follow these precautions may result in hazards.

DO NOT ALLOW untrained personnel to operate, clean, inspect, repair, or tamper with this instrument.

INTRODUCTION

The **WT 14** is a weight transmitter designed to be paired with load cells for weight measurement in various applications.

The module is easy to install and should be mounted on a **DIN 35 mm (1,3779 inch)** rail or **OMEGA** bar. The display allows for easy reading of weight, instrument status, configuration parameters, and errors.

The four buttons located below the display enable the operator to easily perform functions such as **ZERO**, **TARE**, **Gross/Net** switching, weight threshold setting, configuration, and both theoretical and real calibration.

The **WT 14** uses an **RS232** serial port with **ASCII** protocols, allowing connection to **PCs**, **PLCs**, and remote units with a maximum distance of 15 meters (49.21 feet). For longer distances, the **RS422/RS485** serial output is required, supporting the **MODBUS RTU** protocol for up to **32** addressable instruments.

The availability of the most common fieldbus interfaces, as an alternative to the **RS485** port, allows the transmitter to be connected to any supervisory device available on the market.

A **USB 2.0** port is also available, facilitating connection to **PCs** via the included software utility.

The device always features two programmable weight thresholds and peak weight control (maximum weight reached).

Additionally, an analog output in voltage or current is available, even when using **FIELDBUS** communication.

AVAILABLE VERSIONS:

- **WT 14:** Weight transmitter with RS232, USB, and RS485 serial output and Peak function. Supported protocols: Modbus RTU, continuous, slave, and on request. Features two programmable setpoints, two inputs, and Peak function.
- **WT 14/A:** Version with analog output.
- **WT 14/PROFINET:** Weight transmitter with RS232, USB, and PROFINET output.
- **WT 14/ETHERNET IP:** Weight transmitter with RS232, USB, and ETHERNET IP output.
- **WT 14/ETHERCAT:** Weight transmitter with RS232, USB, and ETHERCAT output.
- **WT 14/ETHERNET:** Weight transmitter with RS232, USB, and ETHERNET output.
- **WT 14/PROFIBUS:** Weight transmitter with RS232, USB, and PROFIBUS output.
- **WT 14/CANOPEN:** Weight transmitter with RS232, USB, and CANOPEN output.
- **WT 14/DEVICENET:** Weight transmitter with RS232, USB, and DEVICENET output.

TECHNICAL SPECIFICATIONS

SPECIFICATION	VALUE
Power Supply	12÷24 VDC ± 15%
Maximum Power Consumption	5 W
Insulation	Class II
Installation Category	Cat. II
Operating Temperature	-10°C ÷ +50°C (14 °F ÷ 122 °F)(max humidity 85% without condensation)
Storage Temperature	-20°C ÷ +70°C (-4 °F ÷ 158 °F)
Weight Display	6-digit red LED, 7-segment [height 14 mm (0,5512 in)]
LED Indicators	4 LED indicators [3 mm (0,118 in)]
Keyboard	4 keys
Overall Dimensions (W x H x D)	106 mm (4,173 in) x 63 mm (2,48 in) x 110 mm (4,331 in)
Mounting	DIN rail or OMEGA bar
Enclosure Material	Self-extinguishing Noryl (UL 94 V1)
Connections	Removable screw terminal blocks [5.08 mm (20 in) pitch]
Load Cell Power Supply	5 VDC / 120 mA (max 8 cells of 350Ω in parallel), short-circuit protected
Input Sensitivity	0.02 μV min.
Linearity	< 0.01% of full scale
Temperature Drift	< 0.001% of full scale / °C
Internal Resolution	24-bit
Displayed Weight Resolution	Up to 999,999 divisions on usable range
Measurement Range	-3.9 mV/V to +3.9 mV/V
Weight Acquisition Frequency	12 Hz - 1000 Hz
Digital Filter	Selectable 0.5 ÷ 50 Hz (up to 1000 Hz manually)
Weight Decimal Digits	0 to 4 decimal places
Zero and Full Scale Calibration	Automatic (theoretical) or keyboard-executable
Logic Outputs	2 opto-isolated (clean contact) max 24VDC / 100 mA each
Logic Inputs	2 opto-isolated 24 VDC PNP (external power supply)
Serial Ports (2)	RS232C and RS422/485
Maximum Cable Length	15m (49.21 ft) (RS232C) and 1000m (3280.84 ft) (RS422/RS485)
Serial Protocols	ASCII, Modbus RTU
Baud Rate	Selectable: 1200, 2400, 4800, 9600, 19200, 38400, 57600, 115200
USB Device Port	USB 2.0 compliant; speed up to 12 Mbps
Analog Output (Optional)	Opto-isolated 16-bit: Voltage: 0÷5/10 V (R min 10 KΩ), Current: 0/4÷20 mA (R max 300 Ω)
Analog Output Calibration	Via keyboard
Linearity	< 0.02% FS
Thermal Drift	0.001% FS / °C
Microcontroller	ARM Cortex M0+ 32-bit, 256KB Flash, reprogrammable onboard via USB
Data Memory	64 KB expandable up to 1024 KB
Fieldbus (Alternative to RS485)	PROFINET, ETHERNET IP, ETHERCAT, ETHERNET, PROFIBUS, CANOPEN, DEVICENET
Compliance Standards	EN61000-6-2, EN61000-6-3, EN61010-1, EN61326-1, EN45501

INSTALLATION

GENERAL

The **WT 14** consists of a motherboard, which can be equipped with additional optional modules, all housed in a **35 mm (1,378 in) DIN** rail plastic enclosure.

The WT 14 must NOT be immersed in water, exposed to water jets, or cleaned/washed with solvents.

Avoid exposure to heat sources or direct sunlight.

Do NOT install the instrument near high-power devices (e.g., motors, inverters, contactors) or any equipment that does not comply with CE regulations for electromagnetic compatibility.

- The load cell connection cable must have a maximum length of 140m (459.32 ft) / (217,000 in²).
- The RS232 serial line must have a maximum length of **15 meters (49.21 ft)**.
(according to EIA RS-232-C standards).
- Follow the warnings and guidelines specified for connecting each peripheral device.

OVERALL DIMENSIONS

Bottom View:

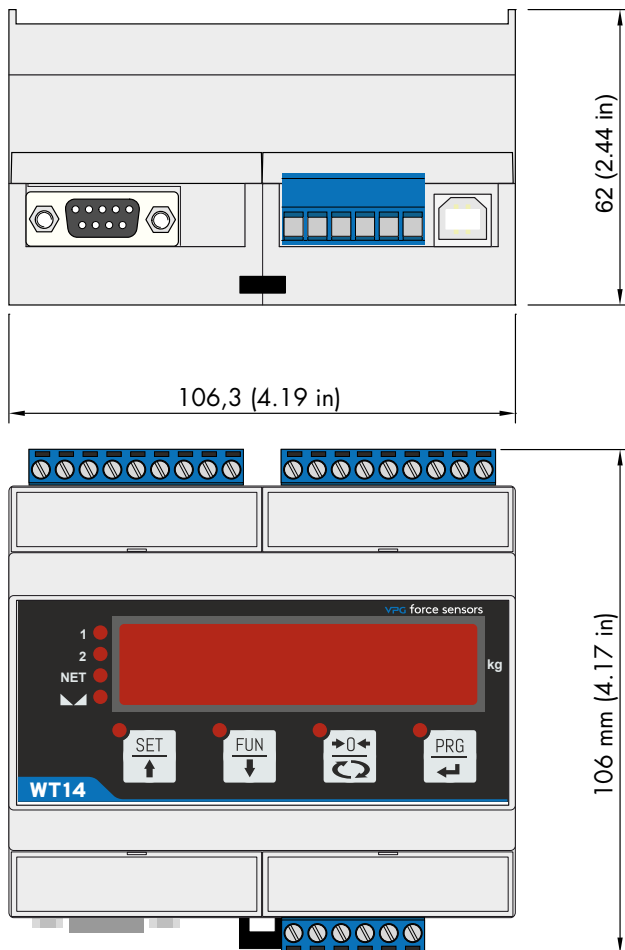

Side View:

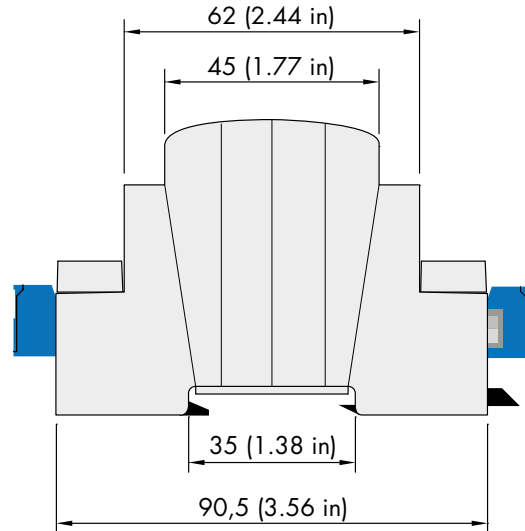

Front View:

ELECTRICAL INSTALLATION

The **WT 14** transmitter uses removable screw terminals with a **5.08 mm (20 in)** pitch for electrical connections. The load cell cable must be shielded and routed away from power cables to avoid electro-magnetic interference.

INSTRUMENT POWER SUPPLY

The instrument is powered through terminals **22** and **23**. The power cable must be routed separately from other cables.



The instrument is classified as insulation class II (double insulation), and a ground terminal is not provided. However, grounding is necessary to connect the cable shields.

Ensure a proper ground connection is in place.

Power supply voltage: 12÷24 VDC ±15%, max 5W.

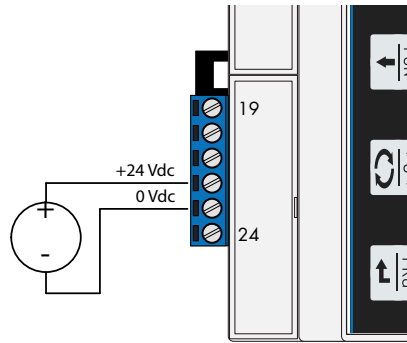

LOAD CELL CONNECTIONS

The load cell cable must not be routed together with other cables but should follow its own dedicated path.

The instrument can be connected to a maximum of **8 load cells** of **350 ohms** in parallel. The load cell supply voltage is **5 VDC** and is protected against temporary short circuits.

The instrument's measurement range supports load cells with sensitivity up to **3.9 mV/V**.

Wiring Instructions:

- Connect the load cell cable to terminals **11** to **18**.
- For a **4-wire** load cell cable, bridge terminal **11** with **14** and **12** with **13**.
- Connect the shield of the load cell cable to terminal **10**.

When using two or more load cells, use appropriate junction boxes (**CEM4/C** or **CSG4/C**), as shown in the connection diagram below.

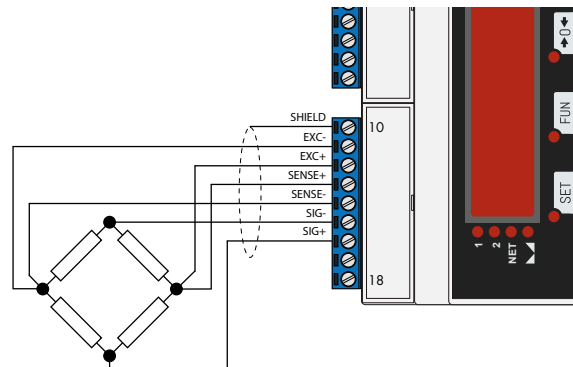

WIRING DIAGRAM FOR J-BOX JBG4 WITH WT 14

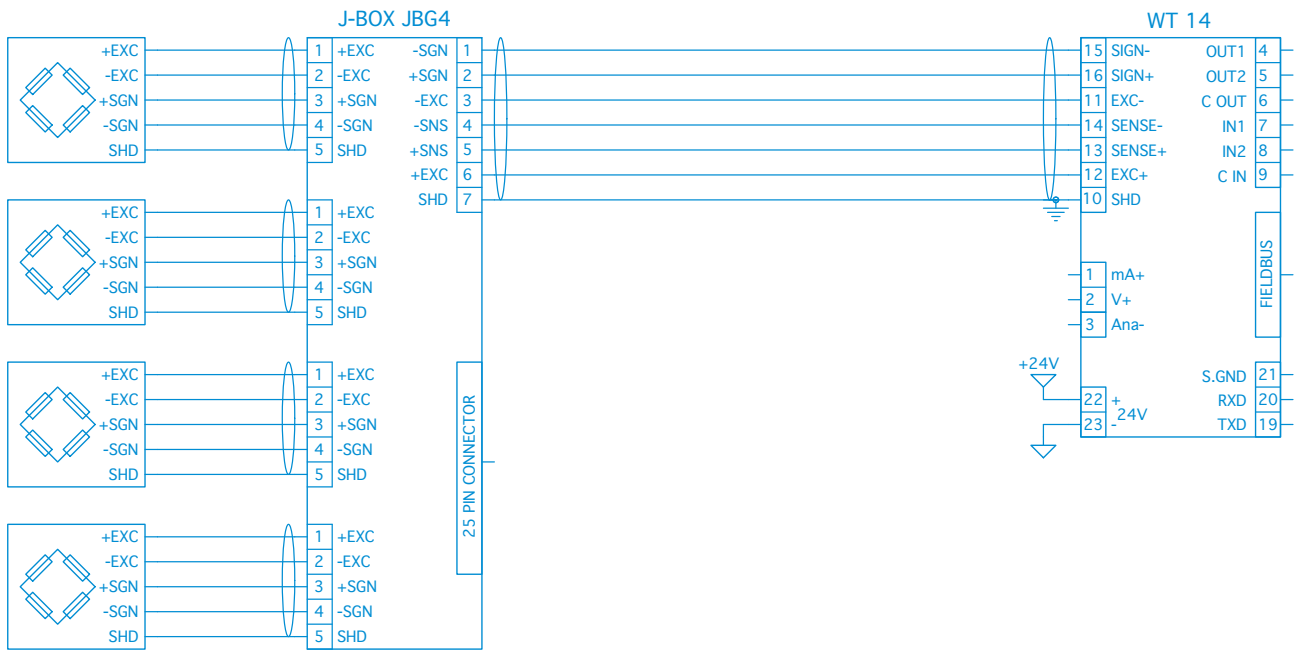

LOGIC INPUTS

The two logic inputs are optoisolated.

- The connection cable for the logic input must not be routed together with power cables.
- Minimize the length of the connection cables.
- The function of the two inputs can be selected via **Set-up**.
- The activation of the two functions is achieved by applying an external **24 VDC** power supply to the corresponding terminals, as shown in the adjacent figure.

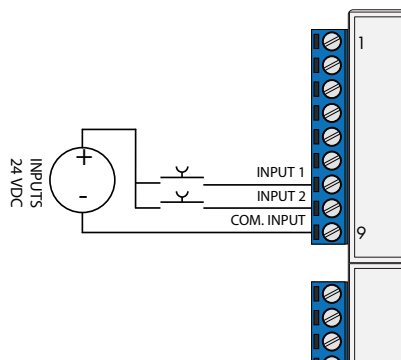

LOGIC OUTPUTS

The two optoisolated relay outputs have a normally open contact.

- Each contact has a capacity of **24 VDC, 100 mA** max.
- The output connection cable must not be routed together with power cables.
- The connection should be kept as short as possible.

Since the installation environment may be exposed to strong magnetic fields and electrical disturbances caused by nearby machinery, it is recommended to take standard precautions to prevent these from affecting the signals of a precision electronic device.

Suggested measures include:

- Filters on contactors
- Diodes on **24 VDC** relays, etc.

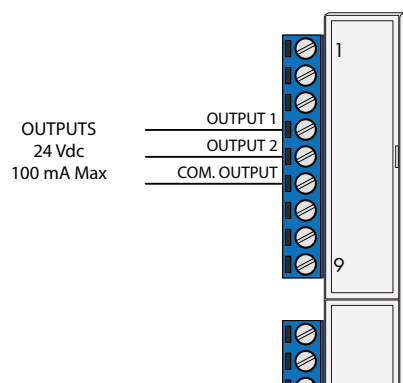

SERIAL COMMUNICATION

RS232

The RS232 serial port is typically used for connections to a **PC**, printer, or repeaters.

- Use a suitable shielded cable for the serial connection.
- Ensure that the shield is grounded at only one end to avoid ground loops.
- The cable must not be routed together with power cables.
- The maximum cable length is **15 meters (49.21 ft)** (according to EIA RS-232-C standards).
- For longer distances, the optional **RS485** interface should be used.

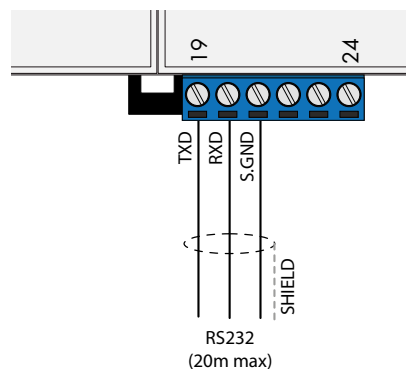

RS485

The RS485 serial connection is a **2-wire** type that allows up to **32 devices** to be connected to a single **MASTER** unit (such as a PC, PLC, etc.) using a twisted and shielded cable.

- Ensure that the shield is grounded at only one end to prevent interference.
- The cable must not be routed together with power cables.

NOTE: Internal connections 6-7 and 4-9 are pre-wired inside the instrument and are only present for compatibility with WT 4 cables.

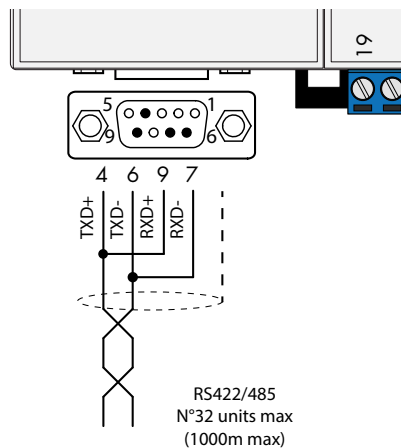

ANALOG OUTPUT (OPTIONAL)

The transmitter provides an **analog output** in either **current or voltage**.

Voltage output:

- **Range:** 0 to 10V or 0 to 5V
- **Minimum load:** 10K Ω

Current output:

- **Range:** 0 to 20 mA or 4 to 20 mA
- **Maximum load:** 300 Ω

Analog transmission can be sensitive to electromagnetic interference, so:

- Keep cables as short as possible and route them separately from other cables.
- Use a **shielded cable**, ensuring that the shield is grounded at only one end.

Warning: Do not connect the analog output to active devices.

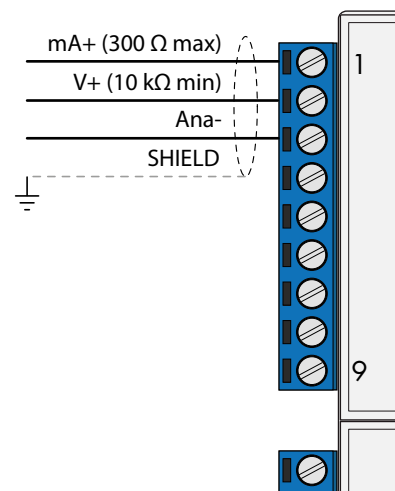

USB DEVICE (SPECIFICATION 2.0 COMPLIANT; FULL-SPEED 12 MBPS)

Use this communication port to directly interface the device with a **PC** via a **USB** port.

- Use a standard **USB** cable for the connection.
- To connect the instrument via the **USB** device port, the appropriate driver must be installed on the **PC** according to the operating system in use.
- Follow the specific installation instructions for proper setup.

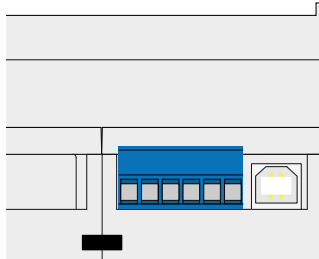

OPTIONAL FIELDBUS CONNECTIONS

As an alternative to the **RS485 serial** port, some of the most widely used fieldbuses are available.

- Only **one fieldbus** can be used, and it must be specified at the time of ordering.

ETHERNET CONNECTION

On the lower left side of the instrument, there is an RJ45 connector for Ethernet networking.

Specifications:

- **Transmission speed:** 10 Mbps
- **Network compatibility:** Supports 10/100/1000 Base-T networks
- **Supported protocols:** Ethernet TCP, Modbus/TCP, UDP, IP, ICMP, ARP
- **Communication mode:** TCP server

LED indicators (2):

- Ethernet link presence
- Communication/diagnostics

Additional Features:

- **Buffer size:** 256 bytes
- **Connection timeout:** Minimum 30 seconds – Maximum 90 seconds
- **Link timeout (disconnected cable):** 30 seconds

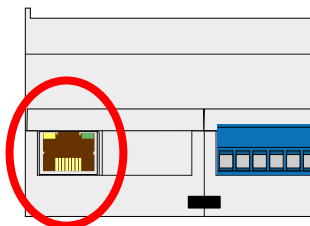

CONNECTION TO MASTER

For connection to the **MASTER**, use a twisted-pair Ethernet cable with an **RJ45** connector.

- The maximum cable length varies depending on the type of cable. A shielded Cat5 cable can reach a maximum length of approximately **180 meters (590.55 ft)**.

Connection Guidelines:

- The **Ethernet communication port** can be directly connected to a PC without passing through network devices (router, switch, hub, LAN bridge, etc.), but this requires a special **"crossover"** RJ45 cable.
- Typically, Ethernet cables are **"straight-through"**, allowing connection to network devices (such as routers or hubs) but not for direct PC-to-PC connections.
- Some modern network cards feature auto-sensing technology, which detects the type of cable and connection, enabling direct PC-to-PC connections even with standard non-crossover cables.

On the side, connection diagrams for both cable types and their corresponding wiring schemes are provided.

PIN	DESCRIPTION
1	TX+
2	TX-
3	RX+
4	
5	
6	RX-
7	
8	

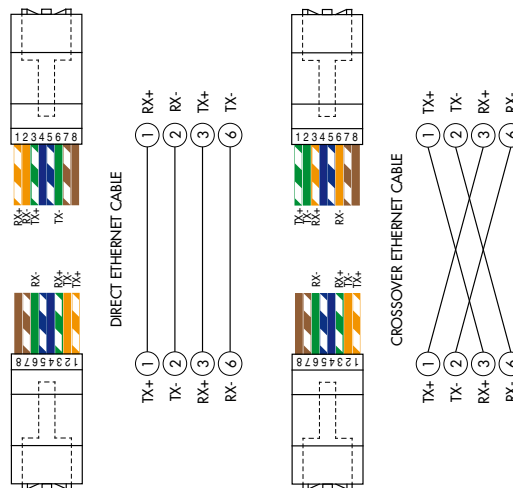

ETHERNET/IP CONNECTION

Ethernet/IP is a real-time industrial protocol based on the Ethernet network.

There are two RJ45 connectors to allow multiple devices to be connected within the same network.

Refer to the description above for connection notes and warnings.

Features:

- 10 and 100 Mbit operation, Full and Half Duplex
- Up to 128 bytes of I/O fieldbus in each direction.

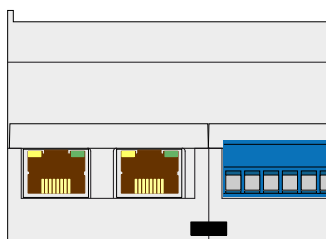

PROFINET CONNECTION

There are two RJ45 connectors to allow multiple devices to be connected within the same network. Refer to the previous page for connection notes and warnings.

Features:

- PROFINET IO Real-Time (RT) communications
- Up to 128 bytes of I/O fieldbus in each direction.

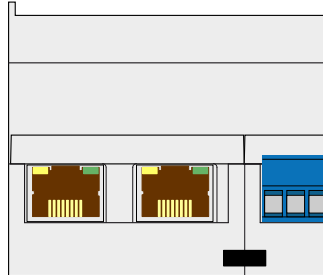

ETHERCAT CONNECTION

EtherCAT is a real-time industrial protocol based on the Ethernet network.

The EtherCAT protocol requires RJ45 connectors to function as IN and OUT.

When connecting multiple **WT 14** devices in series, the MASTER should be connected to the IN connector of the first **WT 14**. The OUT connector of the first device should then be connected to the IN connector of the next device, and so on.

Refer to the previous page for connection notes and warnings.

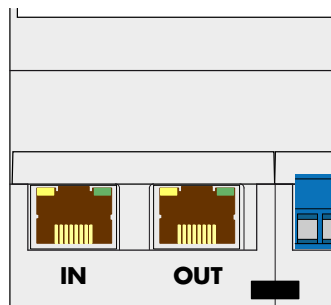

MAC ADDRESS IN DEVICES WITH INDUSTRIAL ETHERNET FIELDBUS.

Devices equipped with Hilscher modules using Industrial Ethernet protocols (Profinet, Ethernet/IP, EtherCAT, etc.) have a label located beneath the connectors, as shown in the figure.

This label contains:

- The MAC Address of the module (highlighted in a red box)
- A unique identification number of the module (highlighted in a blue box)
- A QR code that includes the MAC Address

The **QR code** can be scanned using a smartphone with a **QR reader** app (e.g., "QR Code Reader" available on Google Play Store).



PROFIBUS CONNECTION

Pin	Signal	Description
1	-	Not used
2	-	Not used
3	B line	+RxD / +TxD (RS485 positive signal)
4	RTS	Request to send
5	GND	Ground (isolated)
6	+5V Bus Output	+5V termination power (isolated)
7	-	Not used
8	A line	-RxD / -TxD (RS485 negative signal)
9	-	Not used
Housing	Cable Shield	Internally connected to protective ground as per PROFIBUS specifications

For connection to the **PROFIBUS** Master, use a standard **PROFIBUS** cable. The typical cable impedance should be between **100** and **130 Ω** (for $f > 100$ kHz).

The cable capacitance (measured between conductors) should be less than **60 pF/m (196.85 ft)**, and the minimum conductor cross-section should not be less than **0.22 mm² (0,000341 in²)**.

In a **PROFIBUS-DP** network, both **Type A** and **Type B** cables can be used depending on the required performance. The following table summarizes the characteristics of the cable to be used:

Characteristic	Type A Cable	Type B Cable
Impedance	135 to 165 Ω (f = 3 – 20 MHz)	100 to 300 Ω (f > 100 kHz)
Capacitance	< 30 pF/m (98.43 ft)	< 60 pF/m (196.85 ft)
Resistance	< 110 Ω/km	-
Conductor Cross-Section	> 0.34 mm ² (0,000527 in ²)	> 0.22 mm ² (0,000341 in ²)

The following table shows the maximum line length for **Type A** and **Type B** cables based on different communication speeds:

Baud rate (kbit/s)	9.6	19.2	187.5	500	1500	3000	6000	12000
Max Length (m/ft) Type A Cable	1200 / 3937	1200 / 3937	1000 / 3281	400 / 1312	200 / 656	100 / 328	100 / 328	100 / 328
Max Length (m/ft) Type B Cable	1200 / 3937	1200 / 3937	600 / 1969	200 / 656	-	-	-	-

For reliable Fieldbus operation, line termination should be used at both ends of the network.

If multiple **WT 14** devices are connected, the line termination should be applied to only one device.

For the configuration of the board, the GSD file (hms_1810.gsd) is available and must be installed on the master.

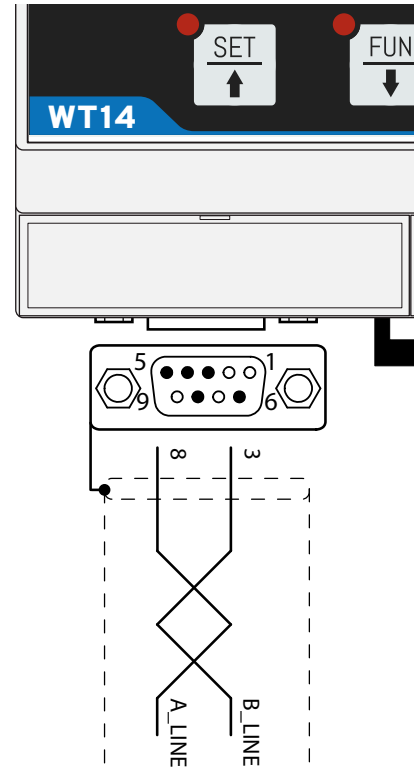

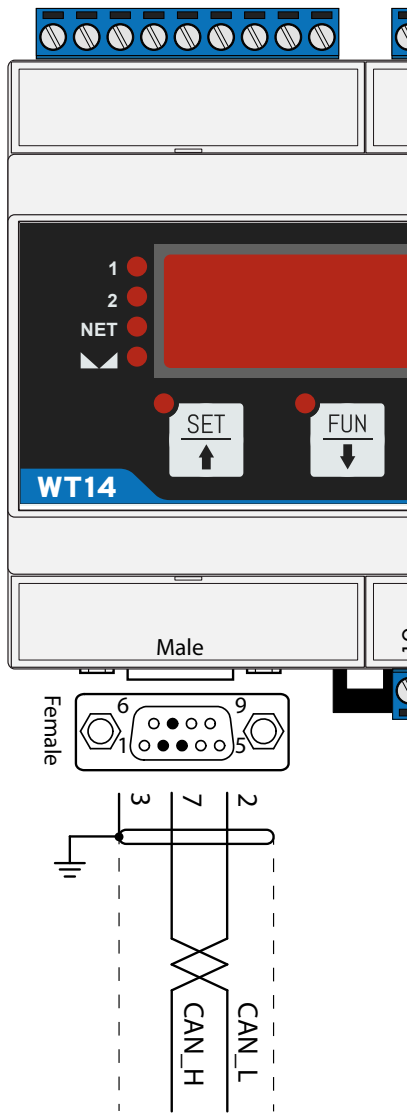

CANOPEN CONNECTION

Pin	Signal	Description
2	CAN_L	CAN low bus line
3	CAN_GND	CAN ground
7	CAN_H	CAN high bus line

CANopen is a higher-layer communication protocol based on the serial CAN bus system.

For the connection, use a differential twisted-pair cable with a common return, in compliance with **ISO 11898**.

The bus length is limited by the selected communication speed, as shown in the following table:

Bit Rate	Max Bus Length (m)	Max Bus Length (ft)
1 Mbit/sec	25	82
500 Kbit/sec	100	328
250 Kbit/sec	250	820
125 Kbit/sec	500	1640
≤ 50 Kbit/sec	1000	3281

The **CAN** line must have a **120Ω** termination resistor at both ends.

The **CAN_GND** reference should be connected to ground at only one point along the line.

The cable should not be routed alongside power cables to avoid interference.

For board configuration, the **ESD** file is available and must be installed on the master.

FRONT PANEL OF THE INSTRUMENT

The **WT 14** features a bright 6-digit display, **4** status **LEDs**, and four buttons, each with a corresponding confirmation **LED**.

In operating mode, the display shows the weight, while the **LEDs** indicate the weight status and threshold levels.

Set-up parameters are easily accessible and adjustable using the front buttons, which allow the user to select, modify, confirm, and save new settings.



DISPLAY

The 6-digit display normally shows the weight of the weighing system.

During various programming procedures, the display is used to enter and store parameters, as well as to show messages indicating the type of operation in progress. These messages assist the operator in managing and programming the instrument.

STAND-BY FUNCTION

The display can enter stand-by mode, during which its brightness is reduced, and the keyboard is locked. However, all other instrument functions remain active and operational.

Refer to the relevant section for details on activating/deactivating stand-by mode.

LED INDICATORS

To the left of the display, there are four **LED** indicators:

1. **Logical Output 1** – On = Contact closed, Off = Contact open
2. **Logical Output 2** – On = Contact closed, Off = Contact open
3. **NET** – The displayed value represents the net weight
4. **> <** – Indicates a stable weight condition

Additionally, each button has a corresponding **LED** that lights up when the button is pressed.

MULTIRANGE FUNCTION

When the multirange function is active (at least one multirange threshold set in the calibration menu), LED 1 and LED 2 are used to indicate the active range:



- **LED 1 ON, LED 2 OFF** → The weight is in Range 1
- **LED 1 OFF, LED 2 ON** → The weight is in Range 2
- **LED 1 ON, LED 2 ON** → The weight is in Range 3

USING THE KEYBOARD







The instrument is programmed and controlled through a 4-button keypad, where each button has a dual function. The instrument automatically determines which function is active based on the current operation.





In general, menu navigation is managed as follows:







- **(Up) ↑ and ↓ (Down)** → Scroll through menu items
- **Enter (↵)** → Access a submenu or an adjustable parameter
- **NO (↶↷)** → Exit the menu or return to the previous level



SYMBOL	DESCRIPTION
	Short press – The corresponding LED briefly flashes
	Long press – The corresponding LED briefly flashes, then stays on until the button is released

Red LED next to each button indicates its activation

BUTTON	FUNCTIONS DURING WEIGHT DISPLAY
	Access the set point programming menu
	Select display mode (Gross weight, Net weight) (Long press) Switch between weight/peak value
	Zero the displayed value (Gross weight, Net weight, or Peak)
	Send weight string via serial line (Long press) Access quick set-up menu
 +  or 	(Press for 3 sec) Access setup menu (Press for 6 sec) Access setup menu.



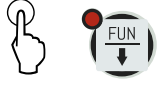



BUTTON	FUNCTION DURING NAVIGATION PROGRAMMING MENU
	Select the next menu
	Select the previous menu
	Exit the programming menu or return to the previous level
	Enter the submenu, access parameter programming, or confirm the selected parameter

BUTTON	FUNCTION WHILE SETTING NUMERICAL VALUES
	Increase the selected digit value
	Decrease the selected digit value
	Select the rightmost digit
	Reset all digits to zero
	Confirm and save the value
	Exit without saving changes





BUTTON	FUNCTION WHILE SETTING PROPOSED VALUES
	Select the next value
	Select the previous value
	Confirm and save the displayed value
	Exit without saving changes

Pressing the  button always moves to the previous menu.

KEYBOARD LOCK/UNLOCK FUNCTIONS

OPERATION	DESCRIPTION
 +  + 	Keyboard Lock – The keys are disabled until unlocked. The display enters low-power mode. The instrument locks when ZERO + PRG are pressed together for 5 seconds. Powering the device off and on will automatically unlock it.
 +  + 	Keyboard Unlock – Pressing ZERO + PRG together for 5 seconds reactivates the keys, and the display brightness returns to normal.

EXITING THE CONFIGURATION MENU

1. Press  to return to the main menu.
2. Press  again; the message "StorE?" will appear.
3. Hold down  until "sEtUP" appears on the display.
4. Press  to return to the weight display screen.

INFO DISPLAY

PdAEd I

When the instrument is powered on, a display test is performed, followed by a sequential display of the software identification code and its version. These codes should be provided when requesting technical support.

When no programming procedure is in progress, the display shows the measured weight in (kg).

In certain conditions, the following messages may appear:

ERROR MESSAGES

In operating mode, the display may show the following error codes:

FIXED MESSAGES



















MESSAGE	DESCRIPTION
<i>P [P iccoE</i>	Displays the peak value
<i>rEiioE</i>	Shown during communication with the PC utility software "VTW Connect"
<i>- - - - -</i>	Overload – The applied weight exceeds the system's maximum capacity by more than 9 divisions
<i>0-L</i>	Load cell signal missing or out of the mV/V measurement range

FLASHING MESSAGE, ALTERNATING WITH THE DETECTED WEIGHT

MESSAGE	DESCRIPTION
<i>No CAL</i>	Weight calibration not performed
<i>No CoN</i>	Fieldbus network disconnected
<i>E-FBUS</i>	Fieldbus interface connection error

OPERATING FUNCTIONS

Once the instrument has been calibrated, on subsequent power-ups, the display shows the current weight. Below are the keyboard operations that can be performed while the weight is displayed:

BUTTON	OPERATION	FUNCTION
		Toggle between Gross Weight and Net Weight
		Display Peak Value
		Auto-Tare (when in Net Weight mode)
		Semi-Automatic Zeroing (when in Gross Weight mode)
		Send a data string via serial (for on-demand protocol) or print (if printer protocol is selected) via RS232
		Set-Point function programming
  + Or 		Enter the Programming Menu
   +		Keyboard Lock – Disables buttons, reduces display brightness, and locks the instrument. Unlocks automatically after a power cycle.
   +		Keyboard Unlock – Reactivates buttons and restores standard display brightness.

GROSS WEIGHT / NET WEIGHT DISPLAY

Press the  button to toggle between **Gross Weight** and **Net Weight** display.

- The **NET LED** indicates the selected mode (**ON** = Net Weight).
- If no tare is applied, the **Net Weight** is equal to the **Gross Weight**.
- If the weight is negative, a **minus sign (-)** appears before the most significant digit.

ZEROING AND AUTO-TARE

Both functions are performed using the  button.

When in Net Weight mode (**NET LED ON**) → The  button performs the Auto-Tare function.

When in Gross Weight mode (**NET LED OFF**) → The  button performs the **Gross Weight Zeroing** function.

ZEROING FUNCTION

The gross weight zeroing command is used to correct small zero drifts in the weighing system during normal operation.

These drifts are typically caused by:

- Thermal variations
- Residual material accumulation over time

Zeroing Conditions:

To execute the zeroing command, the instrument must be in Gross Weight mode (NET LED OFF), and the weight deviation from the scale's zero (set during the zero calibration procedure) must not exceed the number of divisions set in the "0 BAND" parameter (located in the PARAM menu).

When Zeroing is NOT Executed:

The zeroing function will not be performed if any of the following conditions occur:

1. Unstable weight

- If the weight stability control is enabled, zeroing will only take effect if the weight stabilizes within 3 seconds.
- If stability control is disabled ("MOTION" parameter = 0), zeroing is executed regardless of stability.

2. Gross weight exceeds "0 BAND" limit

- If the gross weight (positive or negative) exceeds the number of divisions set in "0 BAND", and no autozero threshold is programmed, zeroing is not allowed.

Memory and Zeroing Limitations:

- The new zero set by the gross weight zeroing function is stored in memory, even after the instrument is powered off.
- Zeroing can be repeated multiple times, but each zeroing operation accumulates the number of divisions.
- If the cumulative zeroing exceeds the limit set in "0 BAND", further zeroing is blocked, and a Zero Calibration must be performed.

Effect of Auto-Zero at Power-On:

- If the AUTO 0 parameter (automatic zeroing at startup) is set, it reduces or eliminates the zeroing range.
- If "AUTO 0" > "0 BAND", the manual zeroing command is completely disabled.

AUTO-TARE FUNCTION

The auto-tare function can be performed only under the following conditions:

- The instrument is in Net Weight mode (NET LED ON)
- The Gross Weight is positive
- The Gross Weight does not exceed the maximum capacity
- The weight is stable

Auto-Tare with Unstable Weight

If the weight is unstable, the system behaves differently based on the **MOTION** parameter:

- **MOTION enabled** ($\neq 0$) → Auto-tare is applied only if the weight stabilizes within 3 seconds after the command is given.
- **MOTION disabled** ($= 0$) → Auto-tare is immediately applied, even with unstable weight.

(For details on the "MOTION" parameter, refer to the corresponding section.)

Memory Retention

The auto-tare value remains stored in memory, even after the instrument is powered off.

PEAK FUNCTION

The instrument continuously records the peak value of the gross weight.

This function is available only if the peak calculation is enabled through the corresponding parameter in the setup menu.

- When peak mode is active, the letter "**P**" appears on the left side of the display.
- The peak value is detected at the same acquisition frequency as the weight (see filter table).

Uses of the Peak Value

In addition to being displayed, the peak value can be used in the following functions:

FUNCTION	DESCRIPTION
LOGIC OUTPUTS	Set-points can be configured to reference the peak value. (See the logic output configuration procedure).
SERIAL PORT	Peak value (peak hold) can be acquired through the following protocols: CONTIN, AUTOM, DEMAND, SLAVE, and MODBUS.
ANALOG OUTPUT	The analog output can be set to follow the peak value (peak hold). (See the analog output configuration procedure).

WEIGHT FREEZE FUNCTION

The acquired weight can be frozen in response to a change in logic inputs, if one of them is configured in **HOLD** mode.

TEST FUNCTIONS – RS232 AND RS485

The test consists of:

- Transmitting the received string back (echo mode).
- Displaying the number of received strings.
- Displaying the number of characters in the last received string.

00C: 00

TEST FUNCTIONS – ANALOG OUTPUT TEST

Once inside the analog output test function (test *out. An*), the following message will appear:

"*out 0*", where 0 represents the output value (current or voltage, depending on the selected mode), expressed as a percentage of full scale.

The output value can be adjusted from 0% to 100% in 10% increments by pressing the 0 button.

Press the **SET** button to exit the function.

TEST FUNCTIONS – INPUT/OUTPUT

When entering the input/output test function (test 1N OUT), the display will show:

"1n 00", where "00" depends on the status of the logic inputs, as described in the following table:

VALUE	MEANING
00	No input active
01	Input 1 active
10	Input 2 active
11	Inputs 1 and 2 active

In the same menu, outputs can be enabled or disabled by repeatedly pressing the **ZERO** button.

- The status of the two outputs is indicated by the first two status **LEDs**.
- Press the **SET** button to exit the function.

WEIGHT THRESHOLD PROGRAMMING

The set threshold values are compared with the measured weight to control the corresponding logic output.

- The comparison criteria are defined in the input/output setup procedure (see the relevant section).
- To access the Set Point settings, press the **SET** button while the weight is displayed.

MENU	MESSAGE	DESCRIPTION	TYPE	DEFAULT	RANGE	FIELD BUS INDEX
Setpoint	SETP. 1	Set Setpoint 1 value	Numeric	0	0 ÷ Full Scale	201 (MSB), 202 (LSB)
	SETP. 2	Set Setpoint 2 value	Numeric	0	0 ÷ Full Scale	203 (MSB), 204 (LSB)

The set threshold values are compared with the measured weight to control the corresponding logic output.

- The comparison criteria are defined in the threshold setup procedure.
- If the weight is undetectable or out of range, all outputs are deactivated (open or closed depending on the MODE setting – see the relevant chapter).
- During the threshold setup phase, both outputs are deactivated.
- If a threshold value is set to 0, the corresponding output will never be activated, regardless of the selected threshold setup mode.

WEIGHT ACQUISITION

The weight can be printed or transmitted via serial port / fieldbus (depending on communication port settings) using the following methods:

Transmission Methods:

- **Automatic mode** → If the serial communication protocol is set to "automatic".
- **Via instrument keyboard** → By pressing the **PRG** button, if the serial communication protocol is set to "on demand".
- **Via external input** → If the protocol is "on demand", and data transmission on demand is assigned to at least one input.
- **Via serial line** → If the protocol is set to "slave", by sending the weighing execution command.
- **Via fieldbus** → By using the weighing execution command in the command register.

Conditions for Weight Acquisition:

- Stable weight (or stabilizing within 3 seconds of the command).
- Since the last acquisition, the weight has changed by at least 20 divisions (delta weight).
- Gross weight must be \geq minimum weight (20 divisions) and \leq full scale capacity.
- Net weight must not be zero.

Metric Mode & Alibi Memory:

- In Metric Mode, if alibi memory is enabled, the transaction is logged.
- The net weight and its identification code are stored in a memory register, accessible via fieldbus upon request.

Free Mode Exceptions:

In Free Mode, when printing is triggered via a button or external input, weighing is allowed even if:

- The gross weight is below the minimum weighing threshold.
- The net weight is zero.

CALIBRATION JUMPER

In metrological use, enabling the setting of metric parameters can be done by placing the jumper inside the board.

CONFIGURATION

GENERAL INFORMATION

All functions of the **WT 14** can be activated and modified through a simple setup menu, which is illustrated on the following page.

- All selected or activated settings are permanently stored, even after the device is powered off.
- The **WT 14** is factory preconfigured with default settings, listed in the following pages.

First Installation & Theoretical Calibration:





During first-time field installation, certain parameters must be adjusted to ensure an accurate weight display (theoretical calibration).



- This calibration can also be requested at the time of purchase.





Setup Modifications:

Setup menu parameters can be modified using:

- The front panel buttons
- The “**VTW Connect**” software utility, included with the device.

KEY	FUNCTION DURING PROGRAMMING (MAIN MENU)
	Selects the next menu.
	Selects the previous menu.
	Exits the programming menu or returns to the previous level.
	Enters the related submenu, programming mode, or confirms selected parameter.

KEY	FUNCTION DURING SETTING SUGGESTED VALUES
	Selects the next value.
	Selects the previous value.
	Confirms and saves the displayed value.

KEY	FUNCTION DURING NUMERIC VALUE SETTING
	Increases the value of the flashing digit.
	Decreases the value of the flashing digit.
	Moves to the next digit.
	Confirms and saves the displayed value.

PROCEDURE FOR MODIFYING AND ENTERING PARAMETERS:

The procedure for accessing the menu depends on the selected operating mode: **FREE** or **METRIC**.

ACCESSING THE MENU IN FREE MODE:

In **FREE** operating mode, all instrument parameters can be modified by the operator.

ACCESSING THE MENU IN METRIC MODE:

In **METRIC** operating mode, weight-related parameters and calibration settings can only be programmed by personnel authorized according to current regulations, via password-protected access.

For this procedure, it is necessary to have the password table available.

DISPLAY	INSTRUCTIONS / ACTIONS REQUIRED
<i>Id</i>	To access the menu, the operator identification code is required. A timed message "ID" will be displayed, after which you will be prompted to enter the code.
<i>0000</i>	Enter the authorized operator's identification code, corresponding to the number in the password table, then confirm by pressing the PRG key. If 0000 is confirmed, or if the operation is canceled by pressing the ZERO key, menu access will be limited (programming of weight parameters and weight calibration settings will not be accessible).
<i>cod.000</i>	A randomly-generated 3-digit number appears on the display. Locate the corresponding 4-digit password in the password table, then press the PRG key to proceed to password entry.
<i>0000</i>	Enter the password obtained from the table, then confirm by pressing the PRG key. If 0000 is confirmed, or if the operation is canceled by pressing the ZERO key, menu access will be limited (programming of weight parameters and weight calibration settings will not be accessible).

Each access by authorized personnel is logged into memory, which stores the last 5 accesses and can be reviewed.

Turn on the instrument with the calibration enable jumper set to the CALIBRATION position to directly access the programming menu.

(Note: When the calibration jumper is active, it is not possible to exit the programming menu.)

"InFo" appears on the display. Use the arrow keys to navigate to the desired menu. Instrument parameters are grouped into several main menus:

MENU	FUNCTION AND DESCRIPTION
InFo	Displays information for instrument identification and configuration details.
TEST	Provides procedures for functional tests of the instrument.
SETUP	Allows programming of parameters that determine instrument operation.

To access the setup menu:

- Press and hold simultaneously the **PRG** and **SET** keys for **3** seconds, OR
- Press and hold only the **PRG** key for at least **6** seconds.

Confirm your selection by pressing the **PRG** key.

MESSAGE	NAME	DESCRIPTION
InFo	Information	Menu displaying parameters for instrument identification and configuration.
TEST	Test	Menu for hardware functional test procedures of the instrument.
SETUP	Setup	Menu containing programmable parameters that determine instrument operation.

INFO MENU

MENU	MESSAGE	NAME	DESCRIPTION	TYPE
InFo	Code FN	Firmware Code	Indicates the installed firmware code	View
	REL FN	Firmware Revision	Indicates the installed firmware revision	View
	F.SCALE	Instrument Full Scale	Indicates the configured full-scale value	View
	F. BUS	Fieldbus Present	Indicates the configured Fieldbus type	View
	Addr.	Fieldbus Address	Indicates the configured Fieldbus address (Visible only for RS485 and Profibus configurations)	View
	IP	Fieldbus IP Address	Indicates the configured Fieldbus IP address (Visible only for ETHERNET/IP configurations)	View
	Subnet	Fieldbus Subnet Mask	Indicates the configured Fieldbus subnet mask (Visible only for ETHERNET/IP configurations)	View
	OUT. An	Analog Output Configuration	Indicates presence and type of analog output (Not present - Unipolar - Bipolar)	View
	MEMory	Optional Memory Configuration	Indicates presence and type of optional memory (None - Alibi memory)	View

In the case of PROFINET Fieldbus: the IP address and Subnet Mask parameters can be programmed directly by the PLC.

TEST MENU

MENU	MESSAGE	NAME	DESCRIPTION	TYPE
TEST	SIGNAL	Cell Signal	Displays the input signal to the instrument in mV/V	View
	H1 RES.	x10 Resolution	Displays the weight with 10 times higher resolution than the set value	View
	PSUPPL.	Power Supply Voltage	Displays the power supply voltage measured by the instrument	View
	MEMORY	Memory Test	Automatic functional test of the optional memory (only if configured)	Test
	In OUT.	I/O Test	I/O test with simultaneous display of inputs and outputs (see specific description)	Test
	RS 232	RS232 Test	RS232 transmission and reception test (see specific description)	Test
	RS 485	RS485 Test	RS485 transmission and reception test (see specific description)	Test
	OUT. AN	Analog Output Test	Analog output test procedure with manual activation of output value (see specific description)	Test

SETUP MENU

MENU	SUBMENU	NAME
SETUP	CALibr.	Calibration Settings (*)
	AnALOG	Analog Output Settings (only if analog output configured)
	CoMPor.	Serial Ports and Fieldbus Settings
	In-OUT.	Logical Input and Output Settings
	PARAM	Metrological Weight Parameter Settings
	FILtEr	Filter Settings
	FUnct	Functional Feature Settings
	CLocK	Date and Time Settings (**)
	uPLdo!!	Upload/Download Stored Setup Data
	AccESS	Viewing Last 5 Authorized Personnel Accesses (***)
AI .MEM	Fiscal Memory Consultation (***)	

(*) This menu item is displayed only in case of **FREE** operation; in the case of **METRIC** operation, access is protected by a password known only to authorized personnel.

(*) This menu item is displayed only if the hardware includes a date-time clock.

(*) These menu items are displayed only in case of **METRIC** operation.

Upon exiting the setup menu, if any parameter changes have been made, the message "StorE" is displayed and must be confirmed with **PRG**.

CONFIGURATION PARAMETERS

All configurable parameters are described on the following pages. At the end of each parameter's description, if available, the corresponding Fieldbus address is indicated. If the parameter is of a selectable type, the value to be entered into the register for the desired selection is indicated within square brackets "[]".

CALIBRATION MENU

Access to this menu is permitted only in **FREE** operating mode or in **METRIC** operating mode, provided password-protected access by authorized personnel.

rESoLU

DIVISION VALUE [1101÷1102]

The value of a single division, expressed in kg. The ratio between the system capacity and the division value determines the system resolution (number of divisions).

When the division value is modified without changing the system capacity, the weight calibration is automatically corrected.

Selectable values:

- 0.0001 - 0.0002 - 0.0005
- 0.001 - 0.002 - 0.005
- 0.01 - 0.02 - 0.05
- 0.1 - 0.2 - 0.5
- 1 - 2 - 5
- 10 - 20 - 50

Default: 1

*The configuration of division values via Fieldbus is performed differently from that done directly through the instrument. Please refer to addresses **1101** and **1102** in the Modbus registers table.*

L.C. CAP.

LOAD CELL CAPACITY [1103-1104]

Defines the value corresponding to the total nominal capacity of the load cells, expressed in kg. In case of systems with a single load cell and "N" fixed supports, enter the load cell capacity value multiplied by the total number of supports. This value represents the full-scale value of the weighing system.

When this parameter is modified, the theoretical weight calibration is recalculated.

Values: from 1 to 999999

Default: 0

LC SEN

LOAD CELL SENSITIVITY [1105]

Set the value corresponding to the average sensitivity of the load cells, expressed in mV/V. Values between 0.0 and 4.0 mV/V are accepted. If no value is programmed, a default of 2.0 mV/V is used.

Following any modification of the sensitivity value, the theoretical weight calibration is automatically recalculated.

Values: from 0.0000 to 4.0000 mV/V

Default: 2.0000 mV/V

SYSTEMS

WEIGHING SYSTEM CAPACITY [1301-1302]

Programming of the useful capacity (net) of the weighing system.

Values: from 0 to Load Cell Capacity

Default: 0

DEAD L

FIXED TARE OF THE WEIGHING SYSTEM [1106-1107]

Programming the fixed tare value of the weighing system.

Values: from 0 to System Capacity Value

Default: 00000

CALTYPE

CALIBRATION TYPE SELECTION

Calibration Type Selection. Upon confirmation, one of the following procedures is initiated.

DEAD !!

DEAD WEIGHT CALIBRATION [501-503]

Selection of the calibration type. Upon confirmation, one of the following procedures will be initiated.

TABLE

TABLE TYPE CALIBRATION [1151-1172]

Allows manual programming of up to 5 calibration points.

The values correspond to those determined by the linearization procedure with sample weights.

In this way, you can copy calibration values previously obtained using sample weights.

RANGE.1

MULTIRANGE 1 [1112 ÷ 1113]

Value of the first threshold for the application of the multirange function (set 0 to disable this control).

Values: from 0 to 999999

Default: 0

RANGE.2

MULTIRANGE 2 [1114 ÷ 1115]

Value of the second threshold for the application of the multirange function (set 0 to disable this control).

Values: from 0 to 999999

Default: 0

PARAMETERS DISPLAYED ONLY IN METRIC MODE

G-CAL

CALIBRATION LOCATION GRAVITY [1108-1109]

Programming the gravity value of the location where calibration is performed.

Values: from 9.77000 to 9.84000

Default: 0

G-USE

GRAVITY AT LOCATION OF USE [1110-1111]

Programming the gravity value of the location where the instrument will be used.

Values: from 9.77000 to 9.84000

Default: 0

CONFIGURATION/CALIBRATION EXAMPLE

By setting the parameters listed above, the theoretical calibration of the **WT 14** full scale is performed. This procedure must be completed with the zero calibration described later. Provided there are no mechanical issues, this procedure ensures good system accuracy (maximum error <1% F.S.).

When the resolution selection (rESOLU) is modified, the full-scale calibration is automatically recalculated. Selections incompatible with the calibration parameters or stored calibration are not accepted.

Example scenario:

A tank weighing 750 kg (empty) with a capacity of 1000 liters needs to be weighed. It contains a product with a specific weight of 1.3 kg/dm³. The desired display resolution is 0.2 kg.

Before starting the configuration, ensure that the load cells are correctly connected to the unit and the tank is empty. Then proceed to set the parameters.

Equipment used:

- 3 load cells, each with a capacity of 1000 kg
- Sensitivities: 2.0015, 2.0008, and 1.9998 mV/V respectively (average sensitivity = 2.0007 mV/V)

Set the following configuration parameters:

L.C. CAP = 3000

L.C. SEN = 2.0007

SYSTEMS = 1500

dEAd L = 0

rESoLU = 0.2

Ensure that the value read in the s1gnAl parameter within the **TEST** menu matches the system's tare weight according to the following proportion:

$$\frac{3000}{2.0007} = \frac{750}{X}$$

Where **X** is the signal value expressed in mV/V corresponding to the theoretical empty tank weight. The expected value should be approximately **0.5 mV/V**.

At this point, you can either proceed with the calibration as described in the next paragraph or exit the configuration menu, saving the entered data.

The instrument should now indicate the value corresponding to the empty tank weight (e.g., 756.8).

You can re-enter the configuration menu, input the weight displayed into the dEad L parameter, and enter the value **756.8**.

Exit the configuration menu again, saving the data.

For enhanced accuracy, prepare certified sample weights or material pre-weighed on a certified scale, then proceed to calibration as described in the next paragraph.

CALIBRATION WITH SAMPLE WEIGHTS

The calibration method described here must be performed using certified sample weights and/or material previously weighed on a certified scale.

Always perform zero calibration before proceeding with full-scale calibration.

During the calibration phase, the display alternates between showing the weight and the message "CAL".

WARNING: *If the instrument is switched off without properly exiting the setup menu, the programming performed will not be saved.*

Note: *If after calibration the system shows linearity errors, ensure that the weighed structure is completely free from mechanical constraints.*

ZERO CALIBRATION

Perform this operation with the scale unloaded (including fixed tare) and the weight stabilized.

To set the system to zero, press the **0** key.

The displayed weight resets to zero, and the display alternates between "CAL" and "0".

You may repeat this operation multiple times if necessary.

FULL-SCALE CALIBRATION

Before performing this operation, place the sample weight onto the scale and wait until stabilization; the display will show a weight value.

To correct the displayed weight, press the **SET** key.

The display will show all digits at **0**, with the first digit on the left flashing.

Use the arrow keys to enter the actual weight loaded on the scale, starting from the flashing digit.

Move to the next digit by pressing the **PRG** key.

Confirming the last digit (furthest to the right) by pressing **PRG** applies the weight correction.

The display will show "SAVE" followed by "CAL", alternating with the entered actual weight value.

If the entered value exceeds the resolution offered by the instrument, the weight will not be accepted, and an error message will briefly appear on the display.

You can always repeat the full-scale calibration procedure if needed.

Press and hold the **PRG** key to return to the "CALibr" menu

LINEARIZATION PROCEDURE

Linearization with Sample Weights (**Long press SET key**)

Up to 5 linearization points on the positive scale can be set.

The progressive number of the linearization points alternates with the current weight on the display.

Press the SET key to set the stabilized sample weight value loaded onto the scale. After confirmation, you will move on to the next point. If 0 is entered, the value will not be saved.

To end the procedure, **press** and **hold** the **PRG** key. It is possible to save fewer than **5** points.

The calibration procedure can always be repeated if necessary.

When programming sample weights, values exceeding the full scale, values lower than the previous point, or unstable weights will not be accepted. If the entered value is accepted, the next point is displayed; otherwise, the same point is prompted again.

The linearization points are automatically cleared whenever theoretical calibration data is changed or a full-scale calibration is performed.

TABLE CALIBRATION

Allows manual programming of up to five calibration points, in addition to the zero value. The values correspond to those determined by the linearization procedure with sample weights.

This feature allows you to view values automatically determined by the linearization procedure, modify them, or manually program them according to predetermined values.

SUBMENU	MESSAGE	NAME	DESCRIPTION	TYPE
TABLE	0 SIG.	Zero Signal	Signal value in mV/V corresponding to the scale zero	Com.
	P1 JAL.	Weight Point 1	Weight value corresponding to the 1st calibration point	Com.
	P1 SIG.	Signal Point 1	Signal value in mV/V corresponding to the 1st calibration point	Com.
	P2 JAL.	Weight Point 2	Weight value corresponding to the 2nd calibration point	Com.
	P2 SIG.	Signal Point 2	Signal value in mV/V corresponding to the 2nd calibration point	Com.
	P3 JAL.	Weight Point 3	Weight value corresponding to the 3rd calibration point	Com.
	P3 SIG.	Signal Point 3	Signal value in mV/V corresponding to the 3rd calibration point	Com.
	P4 JAL.	Weight Point 4	Weight value corresponding to the 4th calibration point	Com.
	P4 SIG.	Signal Point 4	Signal value in mV/V corresponding to the 4th calibration point	Com.
	P5 JAL.	Weight Point 5	Weight value corresponding to the 5th calibration point	Com.
	P5 SIG.	Signal Point 5	Signal value in mV/V corresponding to the 5th calibration point	Com.
	GET 0.	Zero Signal Acquisition	Function to acquire the signal in mV/V corresponding to the scale zero	Spc.

Values programmed as zero are not considered.

The data sheet calibration is automatically canceled whenever a new theoretical calibration or a calibration with sample weights is performed.

After performing the zero signal acquisition function by pressing the relevant key  , the signals in the table are recalculated.



An offset, obtained from the difference between the newly acquired zero signal and the previous zero signal value, is added to each signal value.



EXIT FROM CALIBRATION MENU

To exit the *CALIB* menu, press the key  until "StorEP" appears on the display.

To save the new calibration and exit the setup menu, press the **PRG** key.

It is possible to cancel the zero and full-scale calibrations:

Press  +  to cancel the zero calibration.

Press  +  to cancel the full-scale calibration.

ANALOG OUTPUT PARAMETERS (OPTIONAL)

rAnGE.

ANALOG OUTPUT RANGE [1506]

Selection of the analog output range.

Selectable values:

- $0 \div 10$ Vdc [0]
- $0 \div 5$ Vdc [1]
- $4 \div 20$ mA [2]
- $0 \div 20$ mA [3]

Default: $0 \div 10$ Vdc

ModE.

ANALOG OUTPUT OPERATING MODE [1505]

Selection of the value to associate with the analog output, corresponding to net weight, gross weight, peak, or hold value.

Selectable values:

- NET [0]
- GROSS [1]
- PEAK [2]
- HOLD [3]

Default: NET

An 0.

ANALOG OUTPUT ZERO VALUE [1501-1502]

Analog value to subtract, referenced to the analog output full scale.

An FS.

FULL SCALE [1503-1504]

This is the weight corresponding to the full scale of the analog output.

Configurable value: from 0 to Capacity

Default: Capacity

0 Adj.

ZERO OFFSET ADJUSTMENT

Measure the analog output value using a tester to perform the zero (0) calibration.



Use the  and  keys to adjust the analog output.

Hold the key for a long press to apply a rapid variation.

Press the return key  to go back to the menu.

FS Adj.

FULL-SCALE OFFSET ADJUSTMENT

Measure the analog output value using a tester to perform the full-scale (FS) calibration.

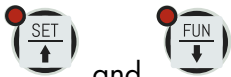

Use the  and  keys to adjust the analog output.

Hold the key for a long press to apply a rapid variation.

Press the return key  to go back to the ANALOG menu.

This procedure is available to the user for adjustment of each selectable range.

In case of a complete setup memory reset (via PC configurator), factory calibrations will be restored.

SERIAL OUTPUT PARAMETERS

This menu allows configuring the COM1 and COM2 serial ports and their communication parameters.

The instrument has two independent serial ports:

COM1: Always with RS232 interface.

COM2: Can be equipped with one of the following interfaces: RS485, PROFINET, ETHERCAT, ETHERNET IP, ETHERNET, PROFIBUS, CANOPEN.

[1 Mod.

RS232 OUTPUT MODE

Selection of the value transmitted via the RS232 output.

Selectable values:

- *nEt*
- *GroSS*
- *PEAk*

Default: *nEt*

[IProt.

COM1 PROTOCOL

Defines the operating mode of the RS232 serial port:

VALUE	DESCRIPTION
None	Serial communication disabled.
Contin	Continuous transmission of the weight string. Used, for example, to drive a weight repeater. See details in the corresponding section.
on deM	When the operator presses the corresponding front button or via input, a weight string is transmitted. The command is accepted if the weight is stable. Between two consecutive transmissions, the weight must change by at least 20 divisions.
Autom	A weight string is automatically transmitted when the weight stabilizes at a value higher than the minimum weight (20 divisions).
Slave	ASCII protocol. See details in the corresponding section.
Print	When the operator presses the corresponding front button or via input, a weight string is transmitted. The command is accepted if the weight is stable. Between two consecutive transmissions, the weight must change by at least 20 divisions.
Riplead	Continuous transmission of the weight string for a special repeater.
Modbus	MODBUS RTU protocol. See details in the corresponding section.

Default: *Slave*

[Ibaud

BAUD RATE COM1

Defines the baud rate for the RS232 serial port.

The value must be set to the same value as the PC/PLC or the remote display.

Selectable values:

- 1200
- 2400
- 4800
- 9600
- 19200
- 38400
- 57600
- 115200

Default: 9600

[IForP

COM1 PROTOCOL

Defines the frame type.

If the **SLAVE** protocol is selected, it is not possible to choose a 7-bit data format (E-7-1 and O-7-1).

Selectable values:

- n-8-1
- n-8-2
- E-7-2
- E-8-1
- o-7-2
- o-8-1

Default: n-8-1

ENOL IN

END-OF-STRING SELECTION

Selection of the end-of-string character for On Demand, Automatic, and Continuous protocols.

Selectable values:

- EOT
- CR-LF

Default: EOT

COM 2 PARAMETERS WHEN PRESENT RS485

[2 Mod

COM2 OUTPUT MODE

Selecting the value transmitted on output RS 485.

Selectable values:

- nEt
- GroSS
- PEAK

Default: nEt

[2Prot

COM2 PROTOCOL

It defines how to use the RS485 serial port:

Selectable values:

VALUE	DESCRIPTION
None	Serial communication OFF.
Contin	Continuous transmission of the weight string. Can be used, for example, to drive a weight repeater. See details in the relevant section.
on deM	When the operator presses the relevant front key or via Input 2, a weight string is transmitted. The command is accepted if the weight is stable. Between two subsequent transmissions, the weight must undergo a variation of at least 20 divisions.
Autom	A weight string is sent automatically when the weight stabilizes at a value above the minimum weight (20 divisions). The weight must vary by at least 20 divisions between two consecutive transmissions.
Slave	ASCII protocol. See details in the relevant section.
Modbus	MODBUS RTU protocol. See details in the relevant section.
Riplead	Continuous weight string transmission for a special repeater.

Default: Slave

[2bAud

COM2 BAUD RATE

Defines the baud rate of serial port RS485.

The value must be set at the same value as PC/PLC or remote display.

Selectable values:

- 1200 - 2400 - 4800 - 9600 - 19200 - 38400 - 57600 - 115200

Default: 9600

[2ForA]

COM2 PROTOCOL

Type of frame. For the **SLAVE** or **MODBUS** protocol you cannot select 7-bit data format (E-7-1 e O-7-1):

Selectable values:

- n-8-1
- n-8-2
- E-7-2
- E-8-1
- o-7-2
- o-8-1

Default: n-8-1

[2Addr.

COM2 ADDRESS

Communication address of the serial port:

Values: from 1 to 32

Default: 1

COM 2 PARAMETERS WHEN PROFINET / ETHERCAT IS PRESENT

EnFbus

FIELD BUS ENABLING

Enabling **PROFINET / ETHERCAT** fieldbus, if **OFF** error messages concerning **FIELD BUS** communication are never displayed:

Selectable values:

- OFF
- ON

Default: OFF

INP.REG.

INPUT AREA DIMENSION

Input area dimension for fieldbus (value expressed in Bytes).

Selectable values:

- 32, 64, 96, 128

Default: 128

OUT.REG.

OUTPUT AREA DIMENSION

Output area dimension for fieldbus (value expressed in Bytes).

Selectable values:

- 32, 64, 96, 128

Default: 128

RES.BUS.

RESET FIELD BUS

Select whether to reset the module in case of NO-COM (no communication).

Selectable values:

- OFF
- ON

Default: OFF

In case of PROFINET fieldbus, the XML configuration file "GSDML-V2.3-HILSCHER-NIC 50-RE PNS 32-20160122.xml" is provided. The size of the input and output areas set in the PLC (possible selections: 32, 64, 96 or 128 bytes) must correspond to the size of the input and output areas selected in the instrument (parameters "INP.REG." and "OUT.REG.").

- **Option / PNet:** GSDML-V2.3-HILSCHER-NIC 50-RE PNS 32- 20160122.xml
- **Option / PNet X90:** GSDML-V2.35-HILSCHER-NETX 90-RE-PNS-32byte- M-20200507.xml

The instruments are supplied with the parameter "Profinet Name" not configured and IP address set at 0.0.0.0.

PARAMETERS COM 2 WHEN ETHERNET IP IS PRESENT

EnFbus

FIELD BUS ENABLING

Enabling ETHERNET IP fieldbus, if OFF error messages concerning Fieldbus communication are never displayed:

Selectable values:

- OFF
- ON

Default: OFF

IP

IP ADDRESS

ETHERNET IP protocol address

Values: from 0.0.0.0 to 255.255.255.255

Default: 0.0.0.0

SubnEt

SUBNET MASK

ETHERNET IP protocol Subnet Mask.

Values: from 0.0.0.0 to 255.255.255.255

Default: 0.0.0.0

InP.rEG

INPUT AREA DIMENSION

Input area dimension for fieldbus (value expressed in Bytes).

Selectable values:

- 32, 64, 96, 128

Default: 128

oUt.rEG

OUTPUT AREA DIMENSION

Output area dimension for fieldbus (value expressed in Bytes).

Selectable values:

- 32, 64, 96, 128

Default: 128

OUT. REG.

RESET FIELD BUS

Select whether to reset the module in case of NO-COM (no communication).

- OFF
- ON

Default: OFF

The **EDS** configuration file to be used for the PLC must be selected based on the configured option, which is specified on the instrument's identification label.

Option / E IP: HILSCHER NIC 50-RE EIS V1.1.EDS

The size of the input and output areas set in the PLC (default input area 128 bytes, default output area 128 bytes) must correspond to the size of the input and output areas selected in the instrument (parameters "INP.REG." and "OUT.REC.").

Option / E IP X90: 4 different EDS configuration files are provided:

- HILSCHER NETX90 EIS V5-32.EDS
- HILSCHER NETX90 EIS V5-64.EDS
- HILSCHER NETX90 EIS V5-96.EDS
- HILSCHER NETX90 EIS V5-128.EDS

The file that corresponds to the size of the input and output areas selected in the instrument must be imported into the PLC (for example if IMP.REG.=128 and OUT.REC.=128 are set in the instrument, the file must be imported into the PLC "HILSCHER NETX90 EIS V5 -128.EDS").

COM 2 PARAMETERS WHEN ETHERNET IS PRESENT

IP

IP ADDRESS

ETHERNET protocol IP address

Values: from 0.0.0.0 to 255.255.255.255

Default: 192.168.0.201

SubnEt

SUBNET MASK

ETHERNET protocol Subnet Mask.

Values: from 0.0.0.0 to 255.255.255.255

Default: 255.255.255.0

GAte

GATEWAY

ETHERNET protocol gateway.

Values: from 0.0.0.0 to 255.255.255.255

Default: 192.168.0.1

Port

PORT

Communication port for ETHERNET protocol.

Values: from 1 to 65535

Default: 1800

Eth.Pro.

ETHERNET COMMUNICATION PROTOCOL

Selecting communication type for Ethernet protocol.

VALUE	DESCRIPTION
None	Serial communication OFF.
Contin	Continuous transmission of the weight string. Can be used, for example, to drive a weight repeater. See details in the relevant section.
on deM	When the operator presses the relevant front button or uses Input 2, a weight string is sent. The command is accepted if the weight is stable. A variation of at least 20 divisions is required between two consecutive transmissions.
Autom	A weight string is sent automatically when the weight stabilizes at a value above the minimum weight (20 divisions).
Slave	ASCII protocol. See details in the relevant section.
Modbus	Modbus TCP protocol.

Default: Slave

COM 2 PARAMETERS WHEN PROFIBUS DP IS PRESENT

EnFbus

FIELD BUS ENABLING

Enabling PROFIBUS DP fieldbus, if OFF error messages concerning Fieldbus communication are never displayed:

Selectable values:

- OFF
- ON

Default: OFF

Addr.Pr

PROFIBUS ADDRESS

Programming the address used in the PROFIBUS protocol.

Values: from 0 to 126

Default: 01

InP.rEG

INPUT AREA DIMENSION

Input area dimension for fieldbus (value expressed in Bytes).

Selectable values:

- 32, 64, 96, 128

Default: 128

oUt.rEG

OUTPUT AREA DIMENSION

Output area dimension for fieldbus (value expressed in Bytes).

Selectable values:

- 32, 64, 96, 128

Default: 128

In the case of PROFIBUS fieldbus, the GSD configuration file "hms_1810.gsd" is provided. The size of the input and output areas set in the PLC (possible selections: 32, 64, 96 or 128 bytes) must correspond to the size of the input and output areas selected in the instrument (parameters "INP.REG." and "OUT.REG.").

Option /E IP: hms_1810.gsd

Option /E IP X90: hil_x90.gsd

COM 2 PARAMETERS WHEN CANOPEN IS PRESENT

EnFbus

FIELDBUS ENABLING

Enabling CANOPEN fieldbus, if OFF error messages concerning Fieldbus communication are never displayed:

Selectable values:

- OFF
- ON

Default: OFF

Addr.Co

CANOPEN ADDRESS

Programming the address used in the CANOPEN protocol.

Values: from 1 to 127

Default: 1

BRud.Co

CANOPEN BAUD RATE

Defines the baud rate of the Canopen protocol.

The value must be set to the same value as the PC / PLC.

Values that can be selected (expressed in Kbit/sec.):

- 10
- 20
- 50
- 125
- 250
- 500
- 1000

Default: 20

COM2 PARAMETERS APPLY WHEN ETHERCAT IS PRESENT

EnFbus

FIELDBUS ENABLING

ETHERCAT fieldbus enabling, if OFF any error messages regarding Fieldbus communication are never displayed:

Selectable values:

- OFF
- ON

Default: OFF

InPrEG

INPUT AREA SIZE

Input area size for fieldbus (value expressed in Bytes).

Selectable values:

- 32, 64, 96, 128

Default: 128

oUt.rEG

OUTPUT AREA SIZE

Output area size for fieldbus (value expressed in Bytes).

Selectable values:

- 32, 64, 96, 128

Default: 128

RE5BUS

RESET FIELDBUS

Select whether to reset the module in case of NO-COM

Selectable values:

- OFF
- ON

Default: OFF

The XML configuration file to be used for the PLC must be selected based on the type of configured option, specified on the instrument identification label. The devices must be connected with a ring type (as per the EtherCAT specification), refer to the manual installation for using the **INPUT** and **OUTPUT** ports.

Option /ECat: 4 different configuration files are provided:

- Hilscher NIC 50-RE ECS V2.2 32 Byte.xml
- Hilscher NIC 50-RE ECS V2.2 64 Byte.xml
- Hilscher NIC 50-RE ECS V2.2 96 Byte.xml
- Hilscher NIC 50-RE ECS V2.2 128 Byte.xml

Opzione /ECat X90: 4 different configuration files are provided:

- Hilscher NETX90 RE ECS V5.2.0-32.xml
- Hilscher NETX90 RE ECS V5.2.0-64.xml
- Hilscher NETX90 RE ECS V5.2.0-96.xml
- Hilscher NETX90 RE ECS V5.2.0-128.xml

The file that corresponds to the size of the input and output areas selected in the instrument must be imported into the PLC (for example if $IMP.REG.=128$ and $OUT.REG.=128$ are set in the instrument, the file must be imported into the PLC "Hilscher NIC 50-RE ECS V2.2 128 Byte.xml"). Multiple files with different sizes can be imported, but in this case it will not be possible to perform the search function and automatic configuration of devices on the network.

INPUT/OUTPUT PARAMETERS

Fun. In. 1

INPUT 1 FUNCTION

Selecting the function associated with input 1. [1401]

VALUE	DESCRIPTION
Zero	Calibrates to zero. [0]
Tare	Executes the automatic tare. [1]
Del.Tar	Cancels the tare. [2]
Peak	Reset of the peak function. [3]
Hold	Holds acquired weight. [4]
Send	Data transmission on demand. [5]
Log	Activates the datalogger function. [6]

Default: Zero

Fun. In. 2

INPUT 2 FUNCTION

Selecting the function associated with input 2. [1402]

VALUE	DESCRIPTION
Zero	Calibrates to zero. [0]
Tare	Executes the automatic tare. [1]
Del.Tar	Cancels the tare. [2]
Peak	Resets the peak function. [3]
Hold	Holds acquired weight. [4]
Send	Data transmission on demand. [5]
Log	Activates the datalogger function. [6]

Default: Zero

Node 1

SET-POINT 1 OPERATING MODE

Select in sequence 4 operating criteria of set-point 1: [1403]

Comparison with net weight, with gross weight or with peak. In the latter case the comparison is carried out with the last acquired peak value, even when the peak function is not active.

VALUE	DESCRIPTION
NET	The relay output is active in Net Weight mode. [0]
GROSS	The relay output is active in Gross Weight mode. [1] (Default)
PEAK	The relay output is active in Peak mode. [2]
PROCESS	The relay output is active when the instrument is working normally. [3]

Default: GROSS

Selecting the output status if normally open or closed: [1404]

VALUE	DESCRIPTION
n.oPEn.	Relay 1 is normally open. [0] (Default)
n.CLOSE	Relay 1 is normally closed. [1]

Default: n. oPEn.

Select if positive or negative values have to be compared. [1405]

VALUE	DESCRIPTION
PoSIt..	The output is operative with positive weight. [0] (Default)
nEGAt.	The output is operative with negative weight. [1]
ALL	The output is operative both with positive and negative weight. [2]

Default: PoSIt

Select whether only stable weight values are to be compared or also unstable: [1406]

VALUE	DESCRIPTION
norMAL	Output 1 is active with unstable weight. [0] (Default)
StAbLE	The output is active with stable weight. [1]

Default: norMAL

Hyst. 1

SET-POINT 1 HYSTERESIS [1407]

Hysteresis value with respect to the set-point

Value: from 0 to Capacity

Default: 2

tINEr 1

SET-POINT 1 TIMING [1408]

Value of time, in tenths of a second, during which, when the weight value set is exceeded, the output associated with set-point 1 remains enabled.

After this time, even if the weight value is still above the set-point, the output is automatically disabled.

The function is not active with programmed time equal to zero.

Values: from 000 to 999

Default: 0

dELAY 1

SET-POINT 1 DELAY [1409]

Value of time, in tenths of a second, after which, when the set weight value is exceeded, the output associated with set-point 1 is enabled.

The function is not active with programmed time equal to zero

Values: from 000 to 999

Default: 0

ModE 2

SET-POINT 2 OPERATING MODE

Select in sequence 4 operating criteria of set-point 2: [1410]

Comparison with net weight, with gross weight or with peak. In the latter case the comparison is carried out with the last acquired peak value, even when the peak function is not active.

VALUE	DESCRIPTION
NET	The relay output is active in Net Weight mode. [0]
GROSS	The relay output is active in Gross Weight mode. [1] (Default)
PEAK	The relay output is active in Peak mode. [2]
PROCESS	The relay output is active when the instrument is working normally. [3]

Default: GROSS

Selecting the output status if normally open or closed: [1411]

VALUE	DESCRIPTION
n.oPEn.	Relay 2 is normally open. [0] (Default)
n.CloSE	Relay 2 is normally closed. [1]

Default: n. oPEn.

Select if positive or negative values have to be compared. [1412]

VALUE	DESCRIPTION
PoSlt..	The output is operative with positive weight. [0] (Default)
nEGAt.	The output is operative with negative weight. [1]
ALL	The output is operative both with positive and negative weight. [2]

Default: PoSlt

Select whether only stable weight values are to be compared or also unstable: [1413]

VALUE	DESCRIPTION
norMAL	Output 2 is active with unstable weight. [0] (Default)
StABLE	Output 2 is active with stable weight. [1]

Default: norMAL

HYSL 2

SET-POINT 2 HYSTERESIS [1414]

Hysteresis value with respect to the set-point

Value: from 0 to Capacity

Default: 2

TIME-2

SET-POINT 2 TIMING [1415]

Value of time, in tenths of a second, during which, when the weight value set is exceeded, the output associated with set-point 2 remains enabled.

After this time, even if the weight value is still above the set-point, the output is automatically disabled.

The function is not active with programmed time equal to zero.

Values: from 000 to 999

Default: 0

DELAY2

SET-POINT 2 DELAY [1416]

Value of time, in tenths of a second, after which, when the set weight value is exceeded, the output associated with set-point 2 is enabled.

The function is not active with programmed time equal to zero

Values: from 000 to 999

Default: 0

WEIGHING PARAMETERS

USE

INSTRUMENT OPERATION

Selecting the operation of the instrument. In case of a change from **FREE** operation to **METRIC** operation, to confirm the setting authentication is required through the password of authorised personnel.

VALUE	VARIATION
Free	Free operation. [0] (Default)
Trade	METRIC instrument operation. [1]

Default: Free

Not Ion

WEIGHT STABILITY [1303]

This parameter defines the number of divisions required for the weight to be considered stable.

A higher number of divisions allows the transmitter to detect weight stability more quickly, which is necessary when performing tare and print commands.

VALUE	VARIATION FROM 0 TO 9
Free	Weight is always considered stable.
Trade	Gradual stability levels (higher values increase accuracy). [1]

Default: 4

AUTO-0

AUTOZERO AT STARTUP [1304-1305]

This parameter defines the maximum weight value that can be zeroed at startup.

This operation corresponds to a zero calibration of the system and is performed only if the weight is stable and below the set value.

Value range: 0 to Full Scale Capacity

Default: 0

0-trAC

ZERO TRACKING [1306]

This function allows you to perform temporary zero calibration compensating for the temperature drift of the weight.

Switching off the transmitter automatically restores the previous zero calibration.

The maximum weight that can be reset by this parameter is **2%** of the capacity of the system.

To disable this function, set the value **0**.

VALUE	VARIATION
0	Control excluded.
1	0.5 divisions per second.
2	1 division per second.
3	2 divisions per second.
4	3 divisions per second.

Default: 0

0-bAnd

ZERO BAND [1307]

This parameter defines the number of divisions that can be reset by pressing the zero button on the front or the associated Input.

Values: from 0 to 200.

Default: 100

FILTER - SETTING FILTER PARAMETERS

d I.G.b.A.n.

WEIGHT FILTER VALUE [1201]

This parameter adjusts not only the refresh rate of the display, but specially the serial and analogue output. The maximum refresh rate of the display is limited to 25 Hz

High filter values speed up the weight update.

Low values of the filter slow down the weight update.

Factor (Hz)	Settling Time (mS)	ADC Freq (Hz)	N readings	Monotony Time (mS)	Oscillation time (mS)	Oscillation range (div)
MANUAL [0]		Selectable	Settable	Settable	Settable	Settable
50 [1]	20	250	5	20	4000	10
25 [2]	40	100	5	40	3000	12
10 [3]	100	50	5	80	2500	16
5 [4]	200	50	10	100	2000	20
2 [5]	500	50	25	250	1500	25
1,25 [6]	800	12,5	10	300	1500	25
1 [7]	1000	12,5	12	400	1500	25
0,7 [8]	1500	12,5	19	500	1200	30
0,5 [9]	2000	12,5	25	600	1000	30

Default: 2 Hz

The following parameters are visible and therefore can be set, only if the parameter selection is **MANUAL**.

E. r.A.t.E.

ADC SPEED [1202]

With this parameter, the frequency of weight acquisition is adjusted. If the parameter changes to values higher than 12.5 Hz, the weight must be stable. In case of instability the instrument will immediately indicate an error message.

Selectable values:

- 12,5 [0]
- 50 [1]
- 100 [2]
- 250 [3]
- 1000 [4]

AJErAG.

NUMBER OF READINGS ON AVERAGE [1203]

With this parameter you set the number of readings that the filter will use to establish the average weight value.

Values: from 0 to 50.

Monot.

MONOTONY TIME [1204]

Parameter used to stabilize the weight when continuous variation of the last digit is detected. Normally used in case of resolution of the weight exceeding 10,000 divisions or with low sensitivity of the input signal. Value expressed in mS.

Values: from 0 to 999.

tOSC IL.

OSCILLATIONS TIME [1205]

Parameter used in conjunction with oscillation Range to reduce the lens weight changes and repetitive typical in lifting systems. Enter the value of the oscillation time expressed in mS.

Values: from 0 to 999.

rOSC IL.

OSCILLATIONS RANGE [1206]

As for the parameter Oscillation time, used to reduce the oscillations. Enter the value of the oscillation expressed in weight divisions.

Values: from 0 to 99.

SETTING FUNCTIONAL FEATURES

StdBY

STAND BY [1001]

Defines the idle time after which the instrument automatically enters low brightness mode and locks the keyboard.

0 = Function disabled.

Value range: 0 to 999

Default: 0

LoCK

KEYBOARD LOCK [1002]

Defines a 4-bit binary setting corresponding to the four keys.

- 0 → not locked
- 1 → locked

(Example: Locks the 2nd and 4th keys.).

Value range: 0000 to 1111

Default: 0000

PInCod

PASSWORD SETTING [1003]

If programmed, a password must be entered to access the programming menu.

For subsequent accesses, re-entering the password is not required until the instrument enters stand-by mode or is powered off.

Value range: 0000 to 9999

Default: 0000 (No password required)

PEAK

PEAK FUNCTION [1004]

Allows enabling or disabling the peak function and selecting whether it refers to net weight or gross weight. If the application does not require this function, it can be disabled.

Selectable values:

- NONE [0]
- NET [1]
- GROSS [2]

Default: NONE

PARAMETERS DISPLAYED ONLY IF OPTIONAL MEMORY IS INSTALLED AND IN FREE MODE

dAtLoG.

DATALOGGER [1005]

Allows you to store the weight and I/O status in Excel format in the optional memory. Logging can be of a single measurement or a continuous series of measurements from the start of storage (max **1000** measurements). The memory can contain a maximum of **60,000** records, beyond which the oldest records are overwritten.

Selectable values:

- NONE [0]
- SINGLE [1]
- CONTIN. [2]

Default: NONE

LoGtRg.

TRIGGER DATALOGGER [1006]

In the case of activated datalogger, select whether the storage occurs manually (from key or input), or when output **1** or **2** is activated. To start storage from the key, press and hold the **SET** button. Storage can be interrupted at any time by pressing the **ZERO** button.

Selectable values:

- MANUAL [0]
- OUT1 [1]
- OUT2 [2]

Default: MANUAL

LoGFrQ.

DATALOGGER FREQUENCY [1007]

If the datalogger is enabled, select the storage frequency of data (datalogger). The maximum frequency corresponds to that of weight acquisition (maximum frequency 250 Hz).

Selectable values:

- 10 MIN. [0]
- 5 MIN. [1]
- 1 MIN. [2]
- 10 SEC. [3]
- 5 SEC. [4]
- 2 SEC. [5]
- 1 HZ [6]
- 5 HZ [7]
- 10 HZ [8]
- HIGH [9]

Default: 10 MIN.

LoGdnL

DOWNLOAD LOG

This function allows downloading the log records through the instrument's **USB** port.

- The process can be interrupted at any time by pressing the **ZERO** key.

At the end of the transmission, the system prompts for log deletion:

- Confirm by pressing **PRG**.
- Cancel by pressing the **ZERO** key.

LoGErS

LOG DELETION

This function allows deleting the log records.

- Confirm deletion by pressing **PRG**.
- Cancel by pressing the **ZERO** key.

NOTE: During the log download function, records are transmitted starting from the oldest record, in the following format:

<Time>	<Gross>	<Net>	<Peak>	<Inputs>	<Outputs>	CR LF
--------	---------	-------	--------	----------	-----------	-------

Or, in Case of Date and Time Option

<Date>	<Time>	<Gross>	<Net>	<Peak>	<Inputs>	<Outputs>	CR LF
--------	--------	---------	-------	--------	----------	-----------	-------

WHERE:

FIELD	DESCRIPTION
Time	6 ASCII characters, right-aligned, representing the recording duration in seconds (range: 0 to 999999, no leading zeros). If the log function is set to store a single record at a time, this field is always 0.
Date	8 ASCII characters representing the recording date in the format "dd/mm/yy".
Time (Hour)	8 ASCII characters representing the recording time in the format "hh:mm:ss".
Gross Weight	8 ASCII characters, right-aligned, representing the gross weight (no leading zeros, including decimal point and negative sign if applicable).
Net Weight	8 ASCII characters, right-aligned, representing the net weight (same format as gross weight).
Peak Weight	8 ASCII characters, right-aligned, representing the peak weight (same format as gross weight).
Inputs	2 ASCII characters: "0" (30h, input inactive) or "1" (31h, input active). These indicate the state of Input 1 and Input 2, respectively.
Outputs	2 ASCII characters: "0" (30h, output inactive) or "1" (31h, output active). These indicate the state of Output 1 and Output 2, respectively.

DATE AND TIME ADJUSTMENT

This menu is visible only if the hardware includes a real-time clock.

DATE

DATE ADJUSTMENT

Parameter for adjusting the current date.

Selectable value format: dd.mm.yy

- **dd:** from 01 to 31
- **mm:** from 01 to 12
- **yy:** from 00 to 99

Default: current date

TIME

TIME ADJUSTMENT

Parameter for adjusting the current time.

Selectable value format: hh:mm

- **hh:** from 00 to 23
- **mm:** from 00 to 59

Default: current time

UPLOAD / DOWNLOAD FUNCTION

The TESTER 1008 must be connected to the COM1 (RS232) serial port of the instrument.

This function allows the download or upload of setup configuration and calibration data stored in the instrument.

- **Download function:** The instrument's setup parameters are saved to a file.
- **Upload function:** The instrument is configured using setup parameters read from a file.

To use these functions, it is necessary to activate the corresponding procedure ("Receive file" or "Transmit file") on the TESTER 1008.

ACCESS VIEWING

This menu is displayed only when operating in **METRIC** mode.

SUBMENU	MESSAGE	NAME	DESCRIPTION	TYPE
ACCESS	ACC-01	Access 01	Procedure for viewing the last access of authorized personnel.	Spc
	ACC-02	Access 02	Procedure for viewing the second-to-last access of authorized personnel.	Spc
	ACC-03	Access 03	Procedure for viewing the third-to-last access of authorized personnel.	Spc
	ACC-04	Access 04	Procedure for viewing the fourth-to-last access of authorized personnel.	Spc
	ACC-05	Access 05	Procedure for viewing the fifth-to-last access of authorized personnel.	Spc

ACCESS VIEWING PROCEDURE

Press PRG to enter: the operator code used to access the instrument's programming and the sequential access number will be displayed as indicated below:

1d.0000

On the display, the identification code used for access (**password table**) is shown.

If the access was performed using the calibration jumper, the identification code **0000** is displayed.

Press the **PRG** button to proceed with viewing the sequential access number.

Pr.0000

The display shows the sequential access number (this value increases with each access and is never reset).

Press the **PRG** button to exit the access viewing procedure.

FISCAL MEMORY CONSULTATION

This menu is displayed only when operating in **METRIC** mode.

SUBMENU	MESSAGE	NAME	DESCRIPTION	TYPE	RANGE
<i>AL .MEN</i>	<i>SEENEN</i>	Fiscal Memory	Procedure for consulting weighings saved in the fiscal memory.	Spc	0÷959999

When operating in **METRIC** mode with fiscal memory enabled:

- Each executed weighing is stored in the fiscal memory.
- Each weighing is assigned a unique identification code with a value between **0** and **959999**.
- The weighing identification code is transmitted via the serial port at the time of weighing.

FISCAL MEMORY CONSULTATION PROCEDURE

000000

Enter the weighing identification code and confirm by pressing the **PRG** button.

0000

The display shows the net weight associated with the requested identification code.

Press the **ZERO** button to exit the fiscal memory consultation procedure.

no Cod.

If the requested identification code is not found in the fiscal memory, the timed message "**NO COD**" is displayed.

SERIAL COMMUNICATION PROTOCOLS

CONTINUOUS, AUTOMATIC, AND MANUAL ASCII PROTOCOL

Continuous transmission occurs at the weight update frequency, depending on the serial transmission baud rate.

When communicating via the Ethernet port, the continuous transmission frequency is limited to **12.5 Hz**.

In **FREE** mode operation, the transmitted string using Continuous, On Demand, or Automatic protocols:

STX	<status>	<weight>	ETX	<chksum>	EOT
-----	----------	----------	-----	----------	-----

In **METRIC Mode Operation**, the Transmitted String Using On Demand and Automatic Protocols:

STX	<status>	<weight>	weighing ID	ETX	<chksum>	EOT
-----	----------	----------	-------------	-----	----------	-----

WHERE:

- **STX** (start of text) = 0x02h
- **ETX** (end of text) = 0x03h
- **EOT** (end of transmission) = 0x04.

<status> = character encoded as per the following table (bit = 1 if condition TRUE):

Bit 7	Bit 6	Bit 5	Bit 4	Bit 3 (Tare Inserted)	Bit 2 (Zero Band)	Bit 1 (Stable Weight)	Bit 0 (Zero Center)
0	0	1	1	Tare Inserted	Zero Band	Stable Weight	Zero Center

WEIGHT AND CHECKSUM FIELD DESCRIPTIONS

<weight> (weight field):

- Composed of **8** ASCII characters.
- Right-justified without leading zeros.
- May include a decimal point and a negative sign if applicable.
- The transmitted weight can be net weight, gross weight, or peak value, depending on the **MODE** parameter set in the serial communication port configuration menu.

SPECIAL CASES FOR <WEIGHT> FIELD

CONDITION	DISPLAYED VALUE
Overweight	"^ ^ ^ ^ ^ ^ ^ ^ ^ ^"
Underweight (> 999999)	" _ _ _ _ _ _ _ _ _ _"
Weight Reading Error	" O-L "

<weighing identification> (weighing identification field):

- Composed of 7 ASCII characters.
- Right-justified without leading zeros.

<chksum> (checksum field):

- Calculated as the exclusive OR (XOR) of all characters from STX (or <Addr>) to ETX, excluding STX and ETX.
- The XOR result is split into two characters, separating the upper 4 bits (first character) and the lower 4 bits (second character).
- The two obtained characters are then encoded in ASCII.
- **Example:** If XOR = 5Dh, the checksum = "5Dh" (which corresponds to 35h and 44h in ASCII).

For automatic and manual communication protocols:

- The weight must change by at least 20 divisions between two consecutive transmissions.

SLAVE PROTOCOL

LIST OF AVAILABLE COMMANDS:

1. Request net weight, gross weight, and peak value.
2. Execute weighing command.
3. Auto-tare command.
4. Semi-automatic zeroing command.
5. Reset peak value command.
6. Program two weight thresholds.
7. Request programmed thresholds.
8. Activate logical outputs.
9. Request logical input status.
10. Store thresholds in permanent memory.
11. Switch display from gross weight to net weight.
12. Switch display from net weight to gross weight.
13. Cancel tare command.
14. Request net weight.
15. Request gross weight.

The unit connected to the instrument (typically a personal computer) acts as the **MASTER** and is the only unit that can initiate a communication procedure.

The communication procedure must always consist of the transmission of a string by the **MASTER**, followed by a response from the addressed **SLAVE**.

CONTROL FORMAT DESCRIPTION

- **Constant Characters:** Enclosed in double quotes (""), case-sensitive.
- **Variable Numeric Fields:** Enclosed in angle brackets (<>).
- **Instrument Identification (<addr>):** Used to identify the specific instrument in the communication network.

ADDRESSING BASED ON COMMUNICATION INTERFACE:

- **RS485:** The <addr> is determined by adding 80h to the instrument's address.
 - **Example:** If the instrument address is 03h, then <addr> = 80h + 03h = 83h.
- **RS232:** The <addr> is always 81h.
- **Ethernet:** The <addr> is always FFh.

COMMAND LIST & FORMATS

	COMMAND NAME	MASTER COMMAND	SLAVE RESPONSE WT 14
1	Request Net, Gross, or Peak Weight	<Addr> "N" EOT	<Addr> "N" <status> <weight> ETX <chksum> EOT or <Addr> NAK EOT

	COMMAND NAME	MASTER COMMAND	SLAVE RESPONSE WT 14
2	Weighing Execution Command	<Addr> "P" EOT	<Addr> "P" <status> <weight> <Weighing ID> ETX <chksum> EOT or <Addr> NAK EOT

This command is available only in METRIC mode. The conditions for its use are:

- Stable weight.
- Since the last weighing, the weight must have changed by at least 20 divisions (weight delta).
- Gross weight must be equal to or greater than the minimum weighing value (20 divisions) and less than the maximum capacity.
- Net weight must not be zero.
- Between two successive requests, the weight must change by 20 divisions; if the weight is unstable, the command will not be executed.

	COMMAND NAME	MASTER COMMAND	SLAVE RESPONSE WT 14
3	Auto-Tare Command	<Addr> "A" EOT	<Addr> "A" ACK EOT or <Addr> NAK EOT

	COMMAND NAME	MASTER COMMAND	SLAVE RESPONSE WT 14
4	Semi-Automatic Zero Command	<Addr> "Z" EOT	<Addr> "Z" ACK EOT or <Addr> NAK EOT

	COMMAND NAME	MASTER COMMAND	SLAVE RESPONSE WT 14
5	Reset Peak Value Command	<Addr> "X" EOT	<Addr> "X" ACK EOT or <Addr> NAK EOT

	COMMAND NAME	MASTER COMMAND	SLAVE RESPONSE WT 14
6	Set Two Weight Thresholds	<Addr> "S" <s1> <s2> ETX <csum> EOT	<Addr> "S" ACK EOT or <Addr> NAK EOT

7	COMMAND NAME	MASTER COMMAND	SLAVE RESPONSE WT 14
	Request Programmed Thresholds	<Addr> "R" EOT	<Addr> "R" <s1> <s2> ETX <csum> EOT or <Addr> NAK EOT

8	COMMAND NAME	MASTER COMMAND	SLAVE RESPONSE WT 14
	Activate Logic Outputs	<Addr> "U" <outputs> EOT	<Addr> "U" ACK EOT or <Addr> NAK EOT

9	COMMAND NAME	MASTER COMMAND	SLAVE RESPONSE WT 14
	Request Logic Input Status	<Addr> "I" EOT	<Addr> "I" <inputs> ETX <csum> EOT or <Addr> NAK EOT

10	COMMAND NAME	MASTER COMMAND	SLAVE RESPONSE WT 14
	Store Thresholds in Memory	<Addr> "E" EOT	<Addr> "E" ACK EOT or <Addr> NAK EOT

In case of a communication error or an unrecognized command from WT 14, it will respond with the following string:

WT 14: <Addr> NAK EOT

- <s1> and <s2>: formatted as a weight field.
- <outputs> and <inputs>: a single ASCII character encoded according to the following table (bit = 1 if the input/output is active).

BIT 7	BIT 6	BIT 5	BIT 4	BIT 3	BIT 2	BIT 1	BIT 0
0	0	1	1	0	0	Input 2 / Output 2	Input 1 / Output 1

11	COMMAND NAME	MASTER COMMAND	SLAVE RESPONSE WT 14
	Display Gross to Net Weight	<Addr> "CN" EOT	<Addr> "C" ACK EOT or <Addr> NAK EOT

12	COMMAND NAME	MASTER COMMAND	SLAVE RESPONSE WT 14
	Display Net to Gross Weight	<Addr> "CL" EOT	<Addr> "C" ACK EOT or <Addr> NAK EOT

13	COMMAND NAME	MASTER COMMAND	SLAVE RESPONSE WT 14
	Delete Tare Command	<Addr> "DT" EOT	<Addr> "D" ACK EOT or <Addr> NAK EOT

14	COMMAND NAME	MASTER COMMAND	SLAVE RESPONSE WT 14
	Request Net Weight (PDAT06)	<Addr> "W" "N" EOT	<Addr> "W" <repeater status> <net weight> ETX <csum> EOT or <Addr> NAK EOT

15	COMMAND NAME	MASTER COMMAND	SLAVE RESPONSE WT 14
	Request Gross Weight (PDAT06)	<Addr> "W" "G" EOT	<Addr> "W" <repeater status> <gross weight> ETX <csum> EOT or <Addr> NAK EOT

WHERE:

<stato rip>: Character encoded according to the following table (bit = 1 if the condition is true).

Bit 7	Bit 6	Bit 5	Bit 4	Bit 3	Bit 2	Bit 1	Bit 0
0	0	1	1	Displayed weight 0 = net 1 = gross	Zero band	Stable weight	Zero center

WEIGHT DATA FORMATTING

The <net> and <gross> fields represent the net and gross weight values, respectively. These fields are 8-character ASCII strings, formatted as follows:

- **Right-aligned:** The weight values are justified to the right within the 8-character field.
- **No Insignificant Zeros:** Leading zeros are omitted.
- Includes **Decimal Points** and **Negative Signs** (if applicable).

SPECIAL CONDITIONS & ERROR STATES

CONDITION	DISPLAYED VALUE	DESCRIPTION
Normal Weight Value	<net> or <gross>	Displays the actual weight value with decimal points and negative signs.
Overweight Condition	"^ ^ ^ ^ ^ ^ ^ ^"	The weight exceeds the maximum measurable capacity.
Extreme Underweight	" _ _ _ _ _"	The weight is below -999999.
Weight Reading Error	" O-L "	A weight reading error has occurred.

PRINTER PROTOCOL

Data transmission protocol to Plus Printer

Printing can be started by pressing a key (see section FUNCTION OPERATIONAL) or by input (see paragraph SETTING I/O).

Here is an example of printer.

```
16/06/16      15:32
Net    209.0 kg
Gross  211.5 kg
Tare   2.5 kg
Peak   268.5 kg
Code   212456
```

- Date is printed only in case of hardware with time clock.
- The peak value is only printed if the peak function is enabled.
- The identification code of the weighing is printed only in case of METRIC operation and alibi memory configured.

The conditions to printing are:

- Stable weight (or stabilized within 3 seconds from command).
- Since the last executed weigh, the weight has undergone a change of at least 20 divisions (delta weight).
- Gross weight equal to or greater than the minimum weight (20 divisions) and less than the maximum capacity.
- Net weight not null.

Only in case of **FREE** functioning, printing is permitted even with gross weight less than the minimum weight or with zero net weight.

MODBUS RTU PROTOCOL

The addresses listed in the tables follow the standard addressing specified in the Modicom PI-MBUS-300 reference guide. Below is an excerpt that helps the user communicate with the device:

“All data addresses in Modbus messages are referenced to zero. The first occurrence of a data item is addressed as item number zero.

For example:

- The coil known as ‘coil 1’ in a programmable controller is addressed as coil 0000 in the data address field of a Modbus message.
- **Coil 127** (decimal) is addressed as **007E** (hex), which corresponds to **126** (decimal).
- Holding register **40001** is addressed as register **0000** in the data address field of the message.
- The function code field already specifies a ‘holding register’ operation, so the ‘**4XXXX**’ reference is implicit.”

To confirm the entry of a new value into the **E2PROM**, it is necessary to execute the **MAKE – BACKUP** function.

If this function is not performed, turning off the **WT 14** will restore the previous value, canceling any modifications made.

Unless otherwise specified, numerical values (such as addresses, codes, and data) are expressed in decimal format.

The **MODBUS RTU** protocol is available only on COM2 RS485.

COMMUNICATION ERROR HANDLING

The communication strings are verified using **CRC** (Cyclical Redundancy Check).

In case of a communication error, the slave does not respond with any string.

The master must consider a timeout for receiving the response.

If no response is received within the expected time, the master must assume that a communication error has occurred.

RECEIVED DATA ERROR HANDLING

If the string is received correctly but cannot be executed, the slave responds with an **EXCEPTION RESPONSE**, as indicated in the following table.

CODE	DESCRIPTION
1	ILLEGAL FUNCTION – The function is not valid or not supported.
2	ILLEGAL DATA ADDRESS – The specified data address is not available.
3	ILLEGAL DATA VALUE – The received data has an invalid value.

SUPPORTED FUNCTIONS

FUNCTION	DESCRIPTION
01	READ COIL STATUS – Read the status of logical outputs.
02	READ INPUT STATUS – Read the status of logical inputs.
03	READ HOLDING REGISTERS – Read programmable registers.
04	READ INPUT REGISTERS – Read "read-only" registers.
05	FORCE SINGLE COIL – Write the status of a single output.
06	PRESET SINGLE REGISTER – Write to a programmable register.
15	FORCE MULTIPLE COILS – Write multiple outputs.
16	PRESET MULTIPLE REGISTERS – Write multiple registers.
Funct + 80h	EXCEPTION RESPONSE

LIST OF HOLDING REGISTERS – MODBUS PROTOCOL

The parameters of the device that can be read or programmed through the available communication interfaces, depending on the hardware configuration, are listed in the following table.

- **R-type registers** are readable.
- **W-type registers** are writable.

For Modbus TCP protocol, the device address ("Unit Identifier" field) must always be set to FFh.

If a fieldbus other than Modbus is used:

- The input area will contain only **R** or **R/W** registers.
- The output area will contain only **W** or **R/W** registers.

All registers have a **16-bit** size.

LIST OF HOLDING REGISTERS – MODBUS PROTOCOL

Address	Holding Register	R/W	Notes
0001	Status Register	R	See related table.
0002	Gross Weight (MSB)	R	INT value - Most Significant Word.
0003	Gross Weight (LSB)	R	INT value - Least Significant Word.
0004	Net Weight (MSB)	R	INT value - Most Significant Word.
0005	Net Weight (LSB)	R	INT value - Least Significant Word.
0006	Peak (MSB)	R	INT value - Most Significant Word.
0007	Peak (LSB)	R	INT value - Least Significant Word.
0008	Digital Inputs / Multirange Status	R	See related table.
0009	Digital Outputs	R	
0101	Weighing Net Weight (MSB)	R	INT value - Most Significant Word.
0102	Weighing Net Weight (LSB)	R	INT value - Least Significant Word.
0103	Weighing Code (MSB)	R	INT value - Most Significant Word.
0104	Weighing Code (LSB)	R	INT value - Least Significant Word.
0201	Set-Point 1 (MSB)	R/W	INT value - Most Significant Word.
0202	Set-Point 1 (LSB)	R/W	INT value - Least Significant Word.
0203	Set-Point 2 (MSB)	R/W	INT value - Most Significant Word.
0204	Set-Point 2 (LSB)	R/W	INT value - Least Significant Word.
0501	Data Register (MSB)	W	INT value - Most Significant Word (See related table).
0502	Data Register (LSB)	W	INT value - Least Significant Word (See related table).
0503	Command Register	W	See related table.
1001	Stand-By Function	R/W	INT value.
1002	Keyboard Lock Function	R/W	See related table.
1003	Password Function	R/W	INT value.
1004	Peak Function	R/W	See corresponding section on page 56.
1005	Data-Logger Function	R/W	See corresponding section on page 57.
1006	Data-Logger Trigger	R/W	See corresponding section on page 57.
1007	Data-Logger Frequency	R/W	See corresponding section on page 57.
1101	Weight Division Value (*)	R/W	See related table.
1102	Decimals (*)	R/W	
1103	Load Cell Capacity (MSB) (*)	R/W	INT value - Most Significant Word.
1104	Load Cell Capacity (LSB) (*)	R/W	INT value - Least Significant Word.
1105	Load Cell Sensitivity (*)	R/W	INT value.
1106	Fixed Tare (MSB) (*)	R/W	INT value - Most Significant Word.
1107	Fixed Tare (LSB) (*)	R/W	INT value - Least Significant Word.
1108	Calibration Gravity (MSB) (*)	R/W	INT value - Most Significant Word.
1109	Calibration Gravity (LSB) (*)	R/W	INT value - Least Significant Word.
1110	Usage Zone Gravity (MSB) (*)	R/W	INT value - Most Significant Word.
1111	Usage Zone Gravity (LSB) (*)	R/W	INT value - Least Significant Word.
1112	Multirange 1 (MSW) (*)	R/W	
1113	Multirange 1 (LSW) (*)	R/W	INT value - Least Significant Word.
1114	Multirange 2 (MSW) (*)	R/W	
1115	Multirange 2 (LSW) (*)	R/W	INT value - Least Significant Word.

1151	Calibration Table - Zero Signal (MSB) (*)	R/W	INT value - Most Significant Word.
1152	Calibration Table - Zero Signal (LSB) (*)	R/W	INT value - Least Significant Word.
1153	Calibration Table - Signal P1 (MSB) (*)	R/W	INT value - Most Significant Word.
1154	Calibration Table - Signal P1 (LSB) (*)	R/W	INT value - Least Significant Word.
1155	Calibration Table - Signal P2 (MSB) (*)	R/W	INT value - Most Significant Word.
1156	Calibration Table - Signal P2 (LSB) (*)	R/W	INT value - Least Significant Word.
1157	Calibration Table - Signal P3 (MSB) (*)	R/W	INT value - Most Significant Word.
1158	Calibration Table - Signal P3 (LSB) (*)	R/W	INT value - Least Significant Word.
1159	Calibration Table - Signal P4 (MSB) (*)	R/W	INT value - Most Significant Word.
1160	Calibration Table - Signal P4 (LSB) (*)	R/W	INT value - Least Significant Word.
1161	Calibration Table - Signal P5 (MSB) (*)	R/W	INT value - Most Significant Word.
1162	Calibration Table - Signal P5 (LSB) (*)	R/W	INT value - Least Significant Word.
1163	Calibration Table - Value P1 (MSB) (*)	R/W	INT value - Most Significant Word.
1164	Calibration Table - Value P1 (LSB) (*)	R/W	INT value - Least Significant Word.
1165	Calibration Table - Value P2 (MSB) (*)	R/W	INT value - Most Significant Word.
1166	Calibration Table - Value P2 (LSB) (*)	R/W	INT value - Least Significant Word.
1167	Calibration Table - Value P3 (MSB) (*)	R/W	INT value - Most Significant Word.
1168	Calibration Table - Value P3 (LSB) (*)	R/W	INT value - Least Significant Word.
1169	Calibration Table - Value P4 (MSB) (*)	R/W	INT value - Most Significant Word.
1170	Calibration Table - Value P4 (LSB) (*)	R/W	INT value - Least Significant Word.
1171	Calibration Table - Value P5 (MSB) (*)	R/W	INT value - Most Significant Word.
1172	Calibration Table - Value P5 (LSB) (*)	R/W	INT value - Least Significant Word.
1201	Filter Factor	R/W	See corresponding section on page 54.
1202	ADC Output Rate	R/W	See corresponding section on page 54.
1203	Number of Readings for Averaging	R/W	INT value.
1204	Monotony Time	R/W	INT value.
1205	Oscillation Time	R/W	INT value.
1206	Oscillation Range	R/W	INT value.
1301	Full Scale (MSB) (*)	R/W	INT value - Most Significant Word.
1302	Full Scale (LSB) (*)	R/W	INT value - Least Significant Word.
1303	Weight Stability (*)	R/W	See corresponding section on page 52.
1304	Autozero at Power-On (MSB) (*)	R/W	INT value - Most Significant Word.
1305	Autozero at Power-On (LSB) (*)	R/W	INT value - Least Significant Word.
1306	Zero Tracking (*)	R/W	See corresponding section on page 52.
1307	Zeroable Divisions (MSB) (*)	R/W	INT value - Most Significant Word.
1308	Zeroable Divisions (LSB) (*)	R/W	INT value - Least Significant Word.
1401	Input Function 1	R/W	See corresponding section on page 49.
1402	Input Function 2	R/W	See corresponding section on page 49.
1403	Output 1 Mode – Function	R/W	See corresponding section on page 49.
1404	Output 1 Mode – Logic	R/W	See corresponding section on page 49.
1405	Output 1 Mode – Polarity	R/W	See corresponding section on page 50.
1406	Output 1 Mode – Stability	R/W	See corresponding section on page 50.
1407	Output 1 Hysteresis	R/W	INT value.
1408	Output 1 Timing	R/W	INT value.

1409	Output 1 Delay	R/W	INT value.
1410	Output 2 Mode – Function	R/W	See corresponding section on page 50.
1411	Output 2 Mode – Logic	R/W	See corresponding section on page 51.
1412	Output 2 Mode – Polarity	R/W	See corresponding section on page 51.
1413	Output 2 Mode – Stability	R/W	See corresponding section on page 51.
1414	Output 2 Hysteresis	R/W	INT value.
1415	Output 2 Timing	R/W	INT value.
1416	Output 2 Delay	R/W	INT value.
1501	Analog Tare (MSB)	R/W	INT value - Most Significant Word.
1502	Analog Tare (LSB)	R/W	INT value - Least Significant Word.
1503	Analog Full Scale (MSB)	R/W	INT value - Most Significant Word.
1504	Analog Full Scale (LSB)	R/W	INT value - Least Significant Word.
1505	Analog Output Mode	R/W	See corresponding section on page 35.
1506	Analog Output Range	R/W	See corresponding section on page 35.
1507	Analog Zero Adjustment	R/W	INT value. Zero output points for analog output. To complete the adjustment procedure, the save data to permanent memory command must be sent to the Command Register.
1508	Analog Full Scale Adjustment	R/W	INT value. Full-scale output points for analog output. To complete the adjustment procedure, the save data to permanent memory command must be sent to the Command Register.
2000	Monitor Register	W	The programmed value is automatically copied to the Monitor Register (2100).
2100	Monitor Register	R	

(*) These registers can only be modified when operating in **FREE** mode or in **METRIC** mode with the calibration jumper enabled.

TABLE A - REGISTER STATUS CODING

BIT	15	14	13	12	11	10	9	8
Description	Setup (***)	Weight difference	Output 2	Output 1	Input 2	Input 1	Run Backup	Hold function
BIT	7	6	5	4	3	2	1	0
Description	Not calibrated	Weight error	Over-load	Under-load	Tare entered	Zero band	Stable weight	Zero centre

TABLE B - KEYPAD LOCK CODING

BIT	15÷3	2	1	0
Description	Not used	UP key	DOWN key	ENTER key

ATTENTION: the bits from 15 to 4 are not managed and are always equal to 0.

TABLE C - INPUT/OUTPUT ENCODING

BIT	15÷6	5 ÷ 4	3 ÷ 2	1	0
Description	Not used	Multirange: • 00 = Disabled • 01 = Field 1 • 10 = Field 2 • 11 = Field 3	Not used	IN 2 Active	IN/OUT 1 Active

TABLE D - DIVISION VALUE AND DECIMAL VALUE ENCODING

ADDRESS	DESCRIPTION	ACCEPTED VALUES
1104	Division Value	1 - 2 - 5 - 10 - 20 - 50
1105	Number of Decimals	0 - 1 - 2 - 3 - 4

TABLE E - COMMAND REGISTER / DATA REGISTER ENCODING

REGISTER VALUE	COMMAND REGISTER FUNCTION	DATA REGISTER FUNCTION
0x0001	Semi-automatic zero	
0x0002	Auto-tare	
0x0003	Peak reset	
0x0004	Zero calibration (**)	
0x0005	Full-scale calibration (**)	Sample weight value in MSB and LSB
0x0006	Analog test	Value between 0 and 100 at 10 intervals in LSB
0x0007	Save data to permanent memory	
0x000A	Weighing execution command	
0x000B	Switch from gross weight to net weight	
0x000C	Switch from net weight to gross weight	
0x000D	Acquisition of zero signal (table calibration)	
0x0015	Store linearization point (**)	Sample weight value in MSB and LSB
0x0055	Interrupt linearization procedure (**)	
0x3FFF	Enable Output Data Area (*)	

Notes:

(*) The parameters managed in the Fieldbus Output Data Area are not modified until this command is sent.

- At power-up, the Output Data Area is completely reset.
- The Fieldbus master must read the parameter values from the Input Data Area and copy them into the corresponding registers of the Output Data Area.
- After copying, the enable command must be sent to the Command Register.
- If this command is not sent, all parameters managed in the Output Data Area will be reset at startup.

(**) This function is available only when operating in **FREE** mode or in **METRIC** mode with the calibration jumper enabled.

(***) The instrument is in configuration mode (the flag is set to **TRUE** when accessing the **SETUP** menu of the instrument or during connection with the "**Optimization**" PC software)..

EXAMPLES

ZERO CALIBRATION

In condition of stable and unloaded scale write hexadecimal value **0004** in Command Register (0503). To permanently store in the memory the new Zero value, write hexadecimal value 0007 in Command Register (0503).

FULL SCALE CALIBRATION

- Put a sample weight on the scale, i.e **1256** kg.
- **Write in Data Register** (0501 and 0502) the hex value of the sample weight: 04E8.
- **Write to the Command Register** (0503), the hexadecimal value 0005.

You can write at the same time the Comand Register and Data Register using the multiple registers function.

To permanently store in the memory the new value, write hexadecimal value 0007 in Command Register (0503).

FIELD BUS LINEARIZATION PROCEDURE

The linearization procedure remotely replicates the operations that can be performed from the keyboard as described in the manual for the dead weight calibration:

- **Zero calibration:** send the command 0x0004; carry out the operation with unloaded scale but complete of the fixed tare, with stabilized weight. The gross weight acquired must be reset. It is possible to repeat this operation several times.
- Up to **5 linearization points** on a positive scale are possible. Program the value of the actual weight loaded and stabilized in the Data Register and send the command 0x0015. It is possible to verify the successful operation by checking the gross weight acquired, the instrument automatically switches to the next linearization point; if the weight is not stable the operation is not carried out. The linearization command (0x0015) can be repeated up to 5 points.
- **End the linearization procedure** by sending the command 0x0055 after the acquisition of the last point. It is possible to store a number of points lower than 5.
- Send the **command 0x0007 to save** the calibration in permanent memory.

INSTRUMENT RESPONSE TIMES

The response time of the instrument varies depending on the programmed parameters and the type of request. The following table outlines the response times:

Measurement update frequency	12,5 Hz	50 Hz	100 Hz	250 Hz	1000 Hz
Analog output update frequency	12,5 Hz	50 Hz	100 Hz	250 Hz	1000 Hz
Fieldbus memory area update and reading frequency	125 Hz	125 Hz	125 Hz	125 Hz	125 Hz
Logic output update frequency	12,5 Hz	50 Hz	100 Hz	250 Hz	1000 Hz
Weight and status acquisition cycle from Modbus RTU (*)	$f_{max} = \frac{1}{\left(\left(\frac{(nchar + 8) * 10}{baud}\right) + 0,004\right)}$				
Weight and status acquisition cycle from ASCII protocol (*)	$f_{max} = \frac{1}{\left(\left(\frac{(nchar + 8) * 10}{baud}\right) + 0,004\right)}$				

Weight and Status Acquisition Cycles

- Weight and status acquisition cycle via Modbus RTU (*)
- Weight and status acquisition cycle via ASCII protocol (*)

(*) *nchar* = sum of the characters in the master's request string (Query) and the **WT 14** response string (Response).

Example:

Requesting status, net weight, and gross weight (**5 registers**) with a baud rate of **115.2 kbit/sec**:

$$1 / \left(\frac{(8+15+8) \times 10}{115200} + 0.004 \right) = 171 \text{ Hz}$$

Exceptions:

E2PROM Backup Command → Max response time = 350 ms

Writing the following registers → Max response time = 550 ms

- Load Cell Capacity
- Load Cell Sensitivity
- Weighing Net Weight
- System Tare
- Filter

THE USE OF SERIAL APPLICATIONS VIA THE USB PORT

The PC software “**VTW Connect**” allows:

- the complete configuration of all setup parameters;
- the testing of different hardware sections;
- the consultation of the instrument documentation;
- the firmware update of the instrument;
- the time-based recording of weight values acquired from the instrument through the Data-logger function;
- the saving and loading of the instrument configuration parameters to/from a file.

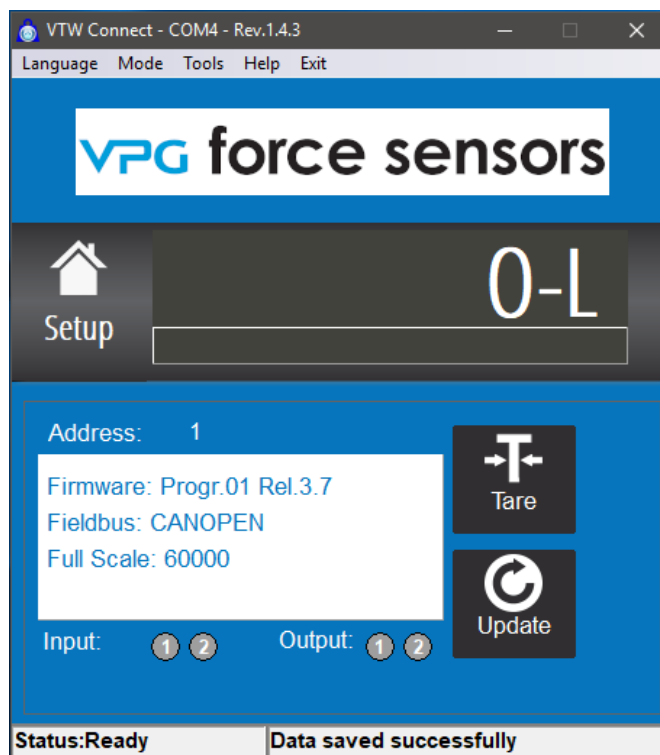

FIELD BUS PROTOCOL

The following table lists the registers of the input area (produced by the instrument and read by the master), common to all fieldbus types: PROFIBUS, PROFINET, ETHERCAT, and ETHERNET/IP.

- The registers have a size of **16** bits.
- The input area is updated at a fixed frequency of **125 Hz** (80 Hz in the case of PROFIBUS fieldbus).
- The size of the Input area configured in the fieldbus master must match the size configured in the instrument.

INPUT DATA AREA

Byte	Register Address	Input Area Register	Notes
1-2	0	Status Register	See relative table.
3-4	1	Gross Weight (MSB)	INT value - Most significant word.
5-6	2	Gross Weight (LSB)	INT value - Least significant word.
7-8	3	Net Weight (MSB)	INT value - Most significant word.
9-10	4	Net Weight (LSB)	INT value - Least significant word.
11-12	5	Peak (MSB)	INT value - Most significant word.
13-14	6	Peak (LSB)	INT value - Least significant word.
15-16	7	Digital Inputs / Multirange Status	See Relative table.
17-18	8	Digital Outputs	
19-20	9	Monitor Register	Value mirrors the corresponding register in the output area.
21-22	10	Weighed Net Weight (MSB)	INT value - Most significant word.
23-24	11	Weighed Net Weight (LSB)	INT value - Least significant word.
25-26	12	Weighing Code (MSB)	INT value - Most significant word.
27-28	13	Weighing Code (LSB)	INT value - Least significant word.
29-30	14	Set-Point 1 (MSB)	INT value - Most significant word.
31-32	15	Set-Point 1 (LSB)	INT value - Least significant word.
33-34	16	Set-Point 2 (MSB)	INT value - Most significant word.
35-36	17	Set-Point 2 (LSB)	INT value - Least significant word.
37-38	18	Load Cell Capacity (MSB)	INT value - Most significant word.
39-40	19	Load Cell Capacity (LSB)	INT value - Least significant word.
41-42	20	Load Cell Sensitivity	INT value.
43-44	21	Weight Division Value	See relative table.
45-46	22	Decimals	See relative table.
47-48	23	Fixed Tare (MSB)	INT value - Most significant word.
49-50	24	Fixed Tare (LSB)	INT value - Least significant word.
51-52	25	Stand-By Function	INT value.
53-54	26	Keyboard Lock Function	See relative table.
55-56	27	Password Function	INT value.
57-58	28	Peak Function	See reference on page 56.
59-60	29	Data-Logger Function	See reference on page 57.
61-62	30	Data-Logger Trigger	See reference on page 57.

63-64	31	Data-Logger Frequency	See reference on page 57.
65-66	32	Filter Factor	See reference on page 54.
67-68	33	ADC Output Rate	See reference on page 54.
69-70	34	Number of Readings for Average	INT value.
71-72	35	Monotony Time	INT value.
73-74	36	Oscillation Time	INT value.
75-76	37	Oscillation Range	INT value.
77-78	38	Full Scale (MSB)	INT value - Most significant word.
79-80	39	Full Scale (LSB)	INT value - Least significant word.
81-82	40	Weight Stability	See reference on page 49.
83-84	41	Autozero on Power-up (MSB)	INT value - Most significant word.
85-86	42	Autozero on Power-up (LSB)	INT value - Least significant word.
87-88	43	Zero Tracking	See reference on page 52.
89-90	44	Input Function 1	See reference on page 49.
91-92	45	Input Function 2	See reference on page 49.
93-94	46	Output Mode 1 - Function	See reference on page 49.
95-96	47	Output Mode 1 - Logic	See reference on page 49.
97-98	48	Output Mode 1 - Polarity	See reference on page 50.
99-100	49	Output Mode 1 - Stability	See reference on page 50.
101-102	50	Output 1 Hysteresis	INT value.
103-104	51	Output 1 Timing	INT value.
105-106	52	Output 1 Delay	INT value.
107-108	53	Output Mode 2 - Function	See reference on page 50.
109-110	54	Output Mode 2 - Logic	See reference on page 51.
111-112	55	Output Mode 2 - Polarity	See reference on page 51.
113-114	56	Output Mode 2 - Stability	See reference on page 51.
115-116	57	Output 2 Hysteresis	INT value.
117-118	58	Output 2 Timing	INT value.
119-120	59	Output 2 Delay	INT value.
121-122	60	Analog Fixed Tare (MSB)	INT value - Most significant word.
123-124	61	Analog Fixed Tare (LSB)	INT value - Least significant word.
125-126	62	Analog Full Scale (MSB)	INT value - Most significant word.
127-128	63	Analog Full Scale (LSB)	INT value - Least significant word.

READING EXAMPLE

To read the gross weight from the **WT 14**, you need to read the address range from 3 to 6 in the Input Area.

To read the net weight, you need to read bytes from 7 to 10 in the Input Area.

If the instrument displays a gross weight value of 12351, the corresponding bytes will be:

	Byte 3	Byte 4	Byte 5	Byte 6
Hex	00	00	30	3F

The following table lists the registers in the Output Data Area (written by the master and acquired by the instrument), common to all fieldbus protocols: PROFIBUS, PROFINET, ETHERCAT, and ETHERNET/IP.

- The registers have a 16-bit size.
- The registers written by the master in the output area are read by the instrument at a fixed frequency of 125 Hz (or 80 Hz for PROFIBUS fieldbus).
- The Output Data Area size configured in the fieldbus master must match the size configured in the instrument to ensure proper communication.

OUTPUT DATA AREA

Byte	Register Address	Output Area Register	Notes
1-2	0	Command Register	See relative table.
3-4	1	Data Register (MSB)	INT value - Most significant word (See Table).
5-6	2	Data Register (LSB)	INT value - Least significant word (See Table).
7-8	3	Monitor Register	Value mirrors the corresponding register in the input area.
9-10	4	Set-Point 1 (MSB)	INT value - Most significant word.
11-12	5	Set-Point 1 (LSB)	INT value - Least significant word.
13-14	6	Set-Point 2 (MSB)	INT value - Most significant word.
15-16	7	Set-Point 2 (LSB)	INT value - Least significant word.
17-18	8	Load Cell Capacity (MSB)	INT value - Most significant word.
19-20	9	Load Cell Capacity (LSB)	INT value - Least significant word.
21-22	10	Load Cell Sensitivity	INT value.
23-24	11	Weight Division Value	See relative table.
25-26	12	Decimals	See relative table.
27-28	13	Fixed Tare (MSB)	INT value - Most significant word.
29-30	14	Fixed Tare (LSB)	INT value - Least significant word.
31-32	15	Stand-By Function	INT value.
33-34	16	Keyboard Lock Function	See relative table.
35-36	17	Password Function	INT value.
37-38	18	Peak Function	See reference on page 56.
39-40	19	Data-Logger Function	See reference on page 57.
41-42	20	Data-Logger Trigger	See reference on page 57.
43-44	21	Data-Logger Frequency	See reference on page 57.
45-46	22	Filter Factor	See reference on page 54.
47-48	23	ADC Output Rate	See reference on page 54.
49-50	24	Number of Readings for Average	INT value.
51-52	25	Monotony Time	INT value.
53-54	26	Oscillation Time	INT value.
55-56	27	Oscillation Range	INT value.
57-58	28	Full Scale (MSB)	INT value - Most significant word.
59-60	29	Full Scale (LSB)	INT value - Least significant word.
61-62	30	Weight Stability	See reference on page 52.
63-64	31	Autozero on Power-up (MSB)	INT value - Most significant word.

65-66	32	Autozero on Power-up (LSB)	INT value - Least significant word.
67-68	33	Zero Tracking	See reference on page 52.
69-70	34	Zeroable Divisions (>0< button)	INT value.
71-72	35	Input Function 1	See reference on page 49.
73-74	36	Input Function 2	See reference on page 49.
75-76	37	Output Mode 1 - Function	See reference on page 49.
77-78	38	Output Mode 1 - Logic	See reference on page 49.
79-80	39	Output Mode 1 - Polarity	See reference on page 50.
81-82	40	Output Mode 1 - Stability	See reference on page 50.
83-84	41	Output 1 Hysteresis	INT value.
85-86	42	Output 1 Timing	INT value.
87-88	43	Output 1 Delay	INT value.
89-90	44	Output Mode 2 - Function	See reference on page 50.
91-92	45	Output Mode 2 - Logic	See reference on page 51.
93-94	46	Output Mode 2 - Polarity	See reference on page 51.
95-96	47	Output Mode 2 - Stability	See reference on page 51.
97-98	48	Output 2 Hysteresis	INT value.
99-100	49	Output 2 Timing	INT value.
101-102	50	Output 2 Delay	INT value.
103-104	51	Analog Fixed Tare (MSB)	INT value - Most significant word.
105-106	52	Analog Fixed Tare (LSB)	INT value - Least significant word.
107-108	53	Analog Full Scale (MSB)	INT value - Most significant word.
109-110	54	Analog Full Scale (LSB)	INT value - Least significant word.
111-112	55	Analog Output Mode	See reference on page 35.
113-114	56	Analog Output Range	See reference on page 35.

(*) These registers can only be modified in **FREE** mode or in **METRIC** mode with the calibration jumper enabled.

WRITING EXAMPLES

To write setup parameters, follow the example below:

1. Unlock Internal Write Area

- Write the HEX value 3FFF to bytes 1-2 (Command Register) to open the internal write area of the **WT 14**.

2. Example Scenario:

- The **WT 14** is programmed with factory values.

Modify the following parameters:

- Load Cell Capacity to 15000
- Load Cell Sensitivity to 2.9965
- Weight Division Value to 2

The necessary values should be written to the corresponding Output Area Registers as per the register table.

Portata	Byte 17	Byte 18	Byte 19	Byte 20
Hex	00	00	3A	98

Sensibilità	Byte 21	Byte 22
Hex	75	0D

Divisione	Byte 23	Byte 24
Hex	00	0A

1. Saving Data:

- Write HEX value 7 to bytes 1-2 (Command Register) to save the modified parameters.
- Note: The **WT 14** does not accept writing a value that is already stored.

2. Zero and Full Scale Calibration:

- No need to enable the internal write area for calibration.

Zero Calibration:

- Ensure the scale is empty.
- Write HEX value 4 to the Command Register.
- The new zero reference is acquired.

Full Scale Calibration:

- Place a known weight on the system.
- Write the corresponding weight value to the Data Register (bytes 3-6).
- Write HEX value 5 to the Command Register.
- The weight value is saved and displayed automatically.

CANOPEN - DESCRIPTION

The protocol supports the CiA DS301 “**communication profile area**”.

Network Management (**NMT**) manages Pre-Operational, Operational, Stopped, Reset and Reset Communication states with its protocols.

The Heartbeat protocol is supported, set by default at 1 second, and can be switched off by programming at 0 the intervention time. (**Index = 1017h**).

The Emergency Message Management intervenes when the following events occur or cease:

- **Fault Sensor** (code = 5030h according to CiA DS404) when the load cell signal is not detected due to failure or incorrect connection or failure of the hardware of the instrument.
- **Sensor Calibration** (code = 6310h based on CiA DS404), when no weight calibration was performed.
- **Input Overload** (code = F001h according to CiA DS404), when the load cell signal is out of the instrument reading range.

Two transmission PDO's are handled with the following transmission types:

- **Synchronous acyclic (00h):** The data is transmitted in response to the **SYNC** signal only if the data has been updated with respect to the previous transmission.
- **Synchronous cyclic (01h):** The data is transmitted in response to the **SYNC** signal even though it has not been updated yet.
- **Asynchronous (FFh):** This is the default operation that involves the transmission of the **PDO** to a predetermined frequency programmable in communication parameters (default = 0, transmission disabled).

The PDO1 is mapped to transmit the following values (updated at 125 Hz frequency):

- **Gross weight** (Index = 2001h), formatted as 32-bit Signed.
- **Net weight** (Index = 2002h), formatted as 32-bit Signed.

The PDO2 is mapped to transmit the following values (updated at 125 Hz frequency):

- **Peak** (index = 2003h), formatted as 32-bit Signed.
- **Status Register** (index = 2000h), formatted as 16-bit Signed.
- **Digital input** (index = 2004h), formatted as 8-bit Unsigned.
- **Output** (index = 2005h), formatted as 8-bit Unsigned.

SPECIFICATIONS

PARAMETER	VALUE
NMT	NMT Slave
Error Control	Heartbeat Producer
Boot-up	Yes
Node ID Range	1 - 127
CANopen Bit Rates	10 – 1000 kbit/sec
Number of PDOs	1 TPDO
PDO Modes	- Event-triggered (timer)
- Synchronous (cyclic)	Yes (6 obj/PDO)
- Synchronous (acyclic)	Yes (Producer)
PDO Mapping	Yes (6 objects/PDO)
Emergency Message	Yes (Producer)
Number of SDOs	1 SDO Server (supports "expedited" and "segmented" transfer)
No SDO Client	-
Sync	- Sync Producer: No
- Sync Counter: No	-
Time Stamp	No
Additional Functions	-
Application Layer	CiA 301 V 4.0.2
Supported Frameworks	-
Supported Profiles	-
Certified	No

CANOPEN - OBJECT DICTIONARY - COMMUNICATION PROFILE AREA

GENERIC PARAMETERS

Index	Sub-Index	Name	Description	Type	Attribute
1000h	0	DEV_TYPE	Device type information (*)	U32	R
1001h	0	ERR_REG	Error log	U8	R
1005h	0	COB_ID SYNC	COB_ID Sync message (80h)	U32	R/W
1010h	0	STORE_PAR	Sub-index number(4)	U8	R
	1		Store all parameters (**)	U32	R/W
	2		Store communication parameters (**)	U32	R/W
	3		Store application parameters (**)	U32	R/W
1011h	0	RESTORE_PAR	Sub-index number(4)	U8	R
	1		Restore default parameters (***)	U32	R/W
	2		Restore communication parameters (***)	U32	R/W
	3		Restore application parameters (***)	U32	R/W
1014h	0	COB_ID EMCY	COB_ID Emergency message (80+Node_ID)	U32	R
1017h	0	HBT_TIME	Heartbeat time (expressed in ms, default 1000 mS)	U16	R/W
1018h	0	OBJ_ID	Sub-index number (4)	U8	CONST
	1		ID Vendor	U32	CONST
	2		Product code	U32	CONST
	3		Version number	U32	CONST

() Parameters can be saved.

(*) Parameters can be restored.

(*) 00070194h (according to CiA DS404 for measurement device).

(**) 65766173h ('a','v','e','s').

(***) 64616F6Ch ('d','a','o','l').

SDO SERVER PARAMETERS

Index	Sub-Index	Name	Description	Type	Attribute
1200h	0	SDO_PAR	SDO record number(2)	U8	R
	1		COB_ID Client->Server (rx) (= 600h + Node_ID)	U32	R
	2		COB_ID Server->Client (tx) (= 580h + Node_ID)	U32	R

T_PDO COMMUNICATION PARAMETERS

Index	Sub-Index	Name	Description	Type	Attribute
1800h	0	AI_T_PDO_CPAR	Sub-index number(5)	U8	R
	1		COB_ID used from PDO (180h + Node_ID)	U32	R
	2		Transmission type PDO (*)	U8	R
	3		Inhibition time (0)	U16	R/W
	4		Reserved	U8	R/W
	5		Event timer (expressed in ms, default 8 ms)	U16	R/W

(*) **PDO Transmission type:**

00h = synchronous acyclic (PDO is transmitted following the receipt of SYNC, but only if a new measurement has been acquired).

01h = synchronous cyclic (PDO is always transmitted after receiving SYNC).

Ffh = asynchronous (default) (PDO is periodically transmitted according to the set time, setting "event timer" to zero, transmission is disabled).

Other types of transmission provided by the CIA DS-301 are not supported.

T_PDO MAPPING PARAMETERS

Index	Sub-Index	Name	Description	Type	Attribute
1A00h	0	T_PDO_MPAR1	Number of "application objects" mapped in the PDO (2)	U8	R
	1		Applic.Obj.map 1 (*)	U32	R
	2		Applic.Obj.map 2 (*)	U32	R

Below is the sub-index structure from **1h** to **6h**.

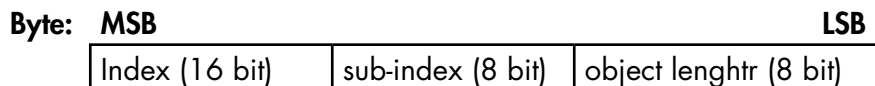

(*) The following default values are defined:

- **Sub-index 0** = 6h.
- **Sub-index 1** = 2001 0120h (Index = 2001h, sub-index 01, 32 bit length).
- **Sub-index 2** = 2002 0120h (Index = 2002h, sub-index 01, 32 bit length).

T_PDO COMMUNICATION PARAMETERS

Index	Sub-Index	Name	Description	Type	Attribute
1801h	0	AI_T_PDO_CPAR2	Sub-index number(5)	U8	R
	1		COB_ID used from PDO (180h + Node_ID)	U32	R
	2		Transmission type PDO (*)	U8	R
	3		Inhibition time (0)	U16	R/W
	4		Reserved	U8	R/W
	5		Event timer (expressed in ms, default 8 ms)	U16	R/W

(*) PDO Transmission type:

00h = synchronous acyclic (PDO is transmitted following the receipt of SYNC, but only if a new measurement has been acquired).

01h = synchronous cyclic (PDO is always transmitted after receiving SYNC).

FFh = asynchronous (default) (PDO is periodically transmitted according to the set time, setting "event timer" to zero, transmission is disabled).

Other types of transmission provided by the **CIA DS-301** are not supported.

T_PDO MAPPING PARAMETERS

Index	Sub-Index	Name	Description	Type	Attribute
1A01h	0	T_PDO_MPAR2	Number of "application objects" mapped in the PDO (2)	U8	R
	1		Applic.Obj.map 1 (*)	U32	R
	2		Applic.Obj.map 2 (*)	U32	R
	3		Applic.Obj.map 3 (*)	U32	R
	4		Applic.Obj.map 4 (*)	U32	R

Below is the sub-index structure from **1h** to **6h**.

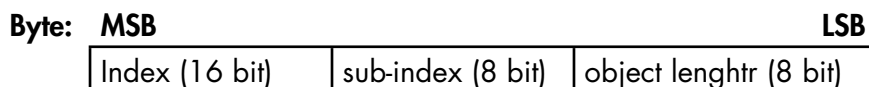

(*) The following default values are defined:

- **Sub-index 0** = 6h.
- **Sub-index 1** = 2003 0120h (Index = 2003h, sub-index 01, 32 bit length).
- **Sub-index 2** = 2000 0110h (Index = 2000h, sub-index 01, 16 bit length).
- **Sub-index 1** = 2004 0120h (Index = 2004h, sub-index 01, 8 bit length).
- **Sub-index 2** = 2005 0120h (Index = 2005h, sub-index 01, 8 bit length).

MANUFACTURER-DEFINED PARAMETERS

Index	Sub-Index	Nome	Description	Type	Attribute
2000h	0	UD_STATUS	Number of sub-index (1)	U8	R
	1		Status Register	U16	R/W
2001h	0	UD_GROSS	Number of sub-index (1)	U8	R
	1		Gross Weight	S32	R
2002h	0	UD_NET	Number of sub-index (1)	U8	R
	1		Net Weight	S32	R
2003h	0	UD_PEAK	Number of sub-index (1)	U8	R
	1		Peak	S32	R
2004h	0	UD_INPUTS	Number of sub-index (1)	U8	R
	1		Digital Inputs	U8	R
2005h	0	UD_OUTPUTS	Number of sub-index (1)	U8	R
	1		Digital Outputs	U8	R
2006h	0	UD_COMMAND	Number of sub-index (1)	U8	R
	1		Command Register	U16	R/W
2007h	0	UD_DATA	Number of sub-index (1)	U8	R
	1		Data Register	U32	R/W
2008h	0	UD_MONITOR_R	Number of sub-index (1)	U8	R
	1		Monitor Register (Read)	U16	R
2009h	0	UD_MONITOR_W	Number of sub-index (1)	U8	R
	1		Monitor Register (Write)	U16	W
200Ah	0	UD_W_VALUE	Number of sub-index (1)	U8	R
	1		Weighed Net Weight	S32	R
200Bh	0	UD_W_CODE	Number of sub-index (1)	U8	R
	1		Weighing Code	S32	R
200Ch	0	UD_SET_1	Number of sub-index (1)	U8	R
	1		Set-Point 1	S32	R/W
200Dh	0	UD_SET_2	Number of sub-index (1)	U8	R
	1		Set-Point 2	S32	R/W
200Eh	0	UD_CAPACITY	Number of sub-index (1)	U8	R
	1		Load Cell Capacity	S32	R/W
200Fh	0	UD_SENSITIVITY	Number of sub-index (1)	U8	R
	1		Load Cell Sensitivity	U16	R/W
2010h	0	UD_DIVISION	Number of sub-index (1)	U8	R
	1		Weight Division Value	U8	R/W

Index	Sub-Index	Nome	Description	Type	Attribute
2011h	0	UD_DEC	Number of sub-index (1)	U8	R
	1		Decimals	U8	R/W
2012h	0	UD_FIXED_TARE	Number of sub-index (1)	U8	R
	1		Fixed Tare	S32	R/W
2013h	0	UD_STANDBY	Number of sub-index (1)	U8	R
	1		Standby Function	U16	R/W
2014h	0	UD_KEY_LOCK	Number of sub-index (1)	U8	R
	1		Keyboard Lock Function	U8	R/W
2015h	0	UD_PASS	Number of sub-index (1)	U8	R
	1		Password Function	U16	R/W
2016h	0	UD_PEAK	Number of sub-index (1)	U8	R
	1		Peak Function	U8	R/W
2017h	0	UD_LOG	Number of sub-index (1)	U8	R
	1		Data Logger Function	U8	R/W
2018h	0	UD_FILTER	Number of sub-index (1)	U8	R
	1		Filter Factor	U8	R/W
2019h	0	UD_RATE	Number of sub-index (1)	U8	R
	1		ADC Output Rate	U8	R/W
201Ah	0	UD_N_AVG	Number of sub-index (1)	U8	R
	1		Number of Readings for Average	U8	R/W
201Bh	0	UD_T_MON	Number of sub-index (1)	U8	R
	1		Monotony Time	U16	R/W
201Ch	0	UD_T_OSC	Number of sub-index (1)	U8	R
	1		Oscillation Time	U16	R/W
201Dh	0	UD_R_OSC	Number of sub-index (1)	U8	R
	1		Oscillation Range	U8	R/W
201Eh	0	UD_FS	Number of sub-index (1)	U8	R
	1		Full Scale	S32	R/W
201Fh	0	UD_STABILITY	Number of sub-index (1)	U8	R
	1		Weight Stability	U8	R/W
2020h	0	UD_AUTO_Z	Number of sub-index (1)	U8	R
	1		Autozero on Power-up	S32	R/W
2021h	0	UD_TRACK_Z	Number of sub-index (1)	U8	R
	1		Zero Tracking	U8	R/W

Index	Sub-Index	Name	Description	Type	Attribute
2022h	0	UD_FUN_IN1	Sub-index number (1)	U8	R
	1		Input 1 function	U8	R/W
2023h	0	UD_FUN_IN2	Sub-index number (1)	U8	R
	1		Input 2 function	U8	R/W
2024h	0	UD_FUN_OUT1	Sub-index number (1)	U8	R
	1		Output 1 mode - Function	U8	R/W
2025h	0	UD_LOG_OUT1	Sub-index number (1)	U8	R
	1		Output 1 mode - Logic	U8	R/W
2026h	0	UD_POL_OUT1	Sub-index number (1)	U8	R
	1		Output 1 mode - Polarity	U8	R/W
2027h	0	UD_STAB_OUT1	Sub-index number (1)	U8	R
	1		Output 1 mode - Stability	U8	R/W
2028h	0	UD_IST_OUT1	Sub-index number (1)	S32	R
	1		Output 1 hysteresis	S32	R/W
2029h	0	UD_T_OUT1	Sub-index number (1)	U8	R
	1		Output 1 timing	U8	R/W
202Ah	0	UD_R_OUT1	Sub-index number (1)	U8	R
	1		Output 1 delay	U8	R/W
202Bh	0	UD_FUN_OUT2	Sub-index number (1)	U8	R
	1		Output 2 mode - Function	U8	R/W
202Ch	0	UD_LOG_OUT2	Sub-index number (1)	U8	R
	1		Output 2 mode - Logic	U8	R/W
202Dh	0	UD_POL_OUT2	Sub-index number (1)	U8	R
	1		Output 2 mode - Polarity	U8	R/W
202Eh	0	UD_STAB_OUT2	Sub-index number (1)	U8	R
	1		Output 2 mode - Stability	U8	R/W
202Fh	0	UD_IST_OUT2	Sub-index number (1)	S32	R
	1		Output 2 hysteresis	S32	R/W
2030h	0	UD_T_OUT2	Sub-index number (1)	U8	R
	1		Output 2 timing	U8	R/W
2031h	0	UD_R_OUT2	Sub-index number (1)	U8	R
	1		Output 2 delay	U8	R/W
2032h	0	UD_ANA_T	Sub-index number (1)	U8	R
	1		Fixed analog tare	U8	R
2033h	0	UD_ANA_FS	Sub-index number (1)	S32	R
	1		Analog full scale	S32	R/W
2034h	0	UD_ANA_M	Sub-index number (1)	U8	R
	1		Analog output mode	U8	R/W
2035h	0	UD_ANA_R	Sub-index number (1)	U8	R
	1		Analog output range	U8	R/W

TROUBLESHOOTING

PROBLEM	POSSIBLE CAUSE	SOLUTION
The display shows the O-L message	The weight cannot be detected because the cell is not available or has been connected incorrectly.	Check the connections of the cells.
The hyphen is shown in the top display.	The acquired weight cannot be shown because it exceeds the available five digits or is greater than the capacity of the cells.	Configure setup parameters that are compatible with system features
The number of decimal places is wrong.	Incorrect division value selected.	Select the correct division value in the main menu.
The Instrument remains switched off	Wrong supply voltage	Power up the instrument with the correct supply voltage
Weight display is frozen	The load cell is not functioning properly or has not been properly connected	Use a multimeter and measure 5Vdc between EXC+ and EXC- and a lower value between SENSE+ and SENSE- (greater are the distance between the instrument and the load cells and lower will be the SENSE voltage) and check the variation in millivolt between SGN+ and SGN- when loading or unloading the load cells
Inputs and / or outputs does not work properly	Wiring or Software Setup Errors	Use the I / O Test Function to verify the correct operation of inputs and outputs and verify the settings of the specific program
The serial communication does not work properly.	Installation has been completed properly. Selection of operation of the serial interface is incorrect.	Check the connections as described in the installation manual. Select the settings as appropriate.
The semi-automatic zero-setting function does not work.	The gross weight exceeds the action limit of semi-automatic zero-setting. The weight doesn't stabilise.	To re-establish the zero, calibrate the weight. Wait for the weight to stabilise or adjust the weight filter parameter.
The semi-automatic tare function does not work.	The gross weight is negative or exceeds the maximum capacity. The weight doesn't stabilise.	Check the gross weight. Wait for the weight to stabilise or adjust the weight filter parameter.

Certificate of Compliance

Certificate Number:
E546509

Report Reference:
E546509-20250306

Issue Date:
2025-06-06

Issued to:

VPG Technology Development Ltd.
Tsela Ha-Har 18, Modi'in Makabim-Re'Ut Israel 7179574
Israel

This certificate confirms that representative samples of:

**AUDIO/VIDEO, INFORMATION AND COMMUNICATION TECHNOLOGY
EQUIPMENT - COMPONENT**
Complementary Recognition Under
**AUDIO/VIDEO, INFORMATION AND COMMUNICATION TECHNOLOGY
EQUIPMENT CERTIFIED FOR CANADA - COMPONENT**

See Addendum Page for Product Designation(s).

Have been evaluated by UL in accordance with the component requirements in the Standard(s) indicated on this Certificate. UL Recognized components are incomplete in certain constructional features or restricted in performance capabilities and are intended for installation in complete equipment submitted for investigation to UL LLC.

UL 62368-1 and CBA C22.2 No. 62368-1:19, Audio/Video, Information and Communication Technology Equipment - Part 1: Safety Requirements

Additional Information:

See the UL Online Certifications Directory at <https://iq.ulprospector.com> for additional information.

This Certificate of Compliance indicates that representative samples of the product described in the certification report have met the requirements for UL certification. It does not provide authorization to apply the UL Recognized Component Mark. Only the Authorization Page that references the Follow-Up Services Procedure for ongoing surveillance provides authorization to apply the UL Mark.

Only those products bearing the UL Recognized Component Mark should be considered as being UL Certified and covered under UL's Follow-Up Services.

Look for the UL Recognized Component Mark on the product.



David Piecuch
UL Mark Certification Program Owner



Any information and dissemination regarding UL Mark services are provided on behalf of UL LLC (UL) or its wholly owned business of UL. For questions, please visit UL Solutions Customer Service at <https://www.ul.com/en/usa>

© 2025 UL LLC. All rights reserved.
Form UL D-013496 – ver 1.0

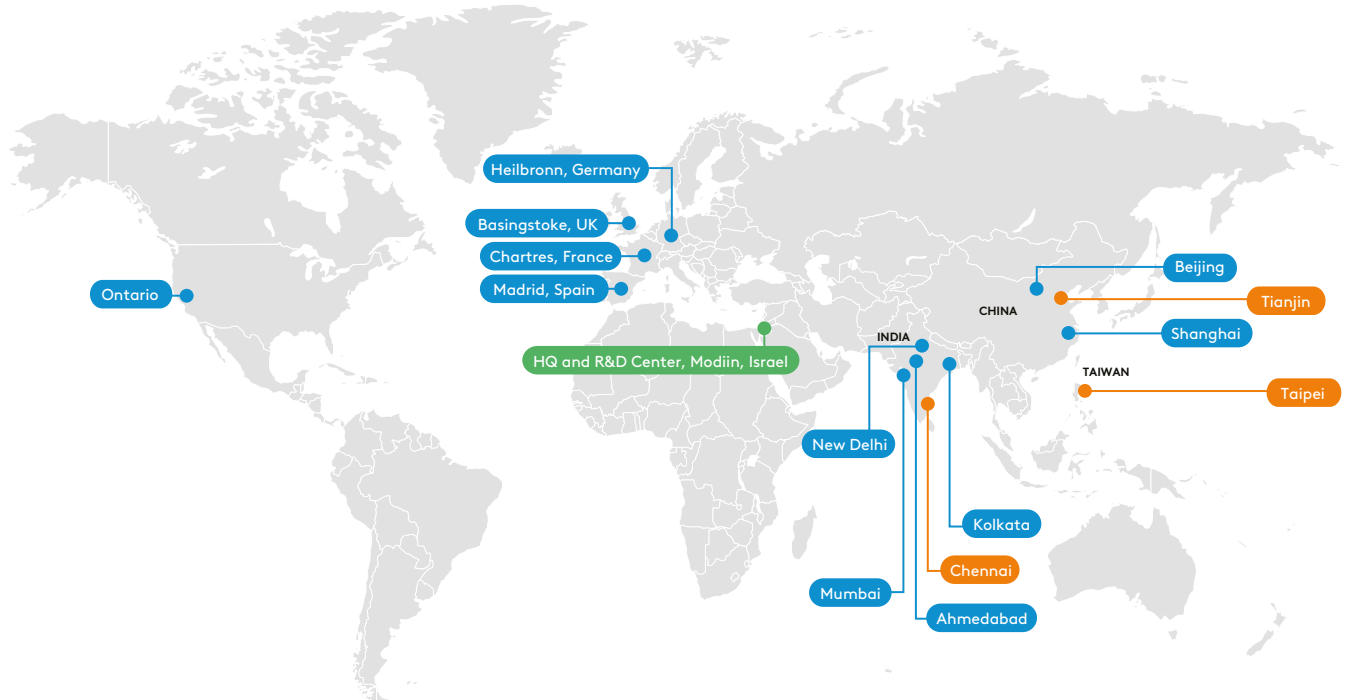

VPG Force Sensors develops and manufactures the world's most advanced force measurement sensors and solutions, delivering optimal performance and empowering tomorrow's innovations. With our renowned brands, we offer the largest range of load cells, weighing instruments and accessories available from a single-source supplier. Chosen for their high accuracy, uncompromising quality and long-lasting reliability, our products are implemented in millions of machines, devices and systems around the world. Due to our large manufacturing capacity, fast turnaround on orders, high product quality and competitive cost structure, we are a leading load cell supplier to many industries and markets. VPG Force Sensors is part of VPG (Vishay Precision Group), a global leader in precision measurement sensing technologies.



Sales Contact

vpgfs.americas@vpgsensors.com

vpgfs.asia@vpgsensors.com

vpgfs.emea@vpgsensors.com

VPG force sensors

Celtron • Revere • Sensortronics • TedeA-Huntleigh



VPGforcesensors.com

DISCLAIMER: ALL PRODUCTS, PRODUCT SPECIFICATIONS AND DATA ARE SUBJECT TO CHANGE WITHOUT NOTICE. Vishay Precision Group, Inc., its affiliates, agents, and employees, and all persons acting on its or their behalf (collectively, "VPG"), disclaim any and all liability for any errors, inaccuracies or incompleteness contained herein or in any other disclosure relating to any product. The product specifications do not expand or otherwise modify VPG's terms and conditions of purchase, including but not limited to, the warranty expressed therein. VPG makes no warranty, representation or guarantee other than as set forth in the terms and conditions of purchase. To the maximum extent permitted by applicable law, VPG disclaims (i) any and all liability arising out of the application or use of any product, (ii) any and all liability, including without limitation special, consequential or incidental damages, and (iii) any and all implied warranties, including warranties of fitness for particular purpose, non-infringement and merchantability. Information provided in datasheets and/or specifications may vary from actual results in different applications and performance may vary over time. Statements regarding the suitability of products for certain types of applications are based on VPG's knowledge of typical requirements that are often placed on VPG products. It is the customer's responsibility to validate that a particular product with the properties described in the product specification is suitable for use in a particular application. You should ensure you have the current version of the relevant information by contacting VPG prior to performing installation or use of the product, such as on our website at vpgsensors.com. No license, express, implied, or otherwise, to any intellectual property rights is granted by this document, or by any conduct of VPG. The products shown herein are not designed for use in life-saving or life-sustaining applications unless otherwise expressly indicated. Customers using or selling VPG products not expressly indicated for use in such applications do so entirely at their own risk and agree to fully indemnify VPG for any damages arising or resulting from such use or sale. Please contact authorized VPG personnel to obtain written terms and conditions regarding products designed for such applications. Product names and markings noted herein may be trademarks of their respective owners.

Revision 15-Sep-2025 EN-17982